

Pedestrian Powered Electric Generator Design

Jared Jorgensen, Brianna Ohlert, Fei Pang, Steven Shapardanis

Department of Engineering
Central Michigan University
Mount Pleasant, MI 48859
Email: jorge2jd@cmich.edu

Introduction

The prevalence of commercially available renewable energy systems has spiked in the last decade, indicating that there is an expanding demand for these types of products. For instance, professionally installed rooftop solar panels have begun to emerge as replacements for traditional roofing tiles and shingles [1]. Wind turbines produce over 1.4 megawatts of power in the state of Michigan annually from wind farms [2]. But small scale residential wind generators which can generate up to ten kilowatts are gaining in popularity. Recently a 20W, pedal powered emergency generator called the *K-Tor Power Box*, was released [3]. These are a few examples of renewable sources directly replacing conventional fuel sources. The goal of this project is to build a stand-alone USB charging station for the front of the Central Michigan University Engineering building that is powered exclusively by the foot traffic through the entrance of the building.

A substantial comparison can be made between our project and the more novel approaches to energy harvesting systems that have begun to emerge. Research has gone into applying piezoelectric plates to capture the kinetic energy of raindrops [4]. Rotating doors with attached dynamos have been produced by Boon Edam Inc, and installed in the Netherland's Driebergen-Zeist railway station. It is expected to produce 4600 kWh annually [5]. Portable solar panels and mobile phone chargers have been on the market for years, such as the *Solio Classic 2*, and can charge a smartphone or tablet from a single day in the sun. Different power generation techniques, energy storage, power electronics circuitry, and specific applications were considered while implementing this project.

Design Considerations

The focus of this project is to implement a reliable, sustainable energy system that can be used by students and visitors in the engineering building. A survey was used to determine what potential consumers thought of the project, and what they'd like to see come from it. The customer needs are depicted in Table 1. The customer's needs were broken down into metrics through which the performance of the project can be measured, shown in Table 2. A quality function deployment chart was then used to relate the metrics to the customer needs, and is shown in Table 3. These metrics were used to guide the design decisions needed for the

application and power generation modules of the project.

Number	Customer Need	Importance
1	Reliability	2
2	Efficiency	3
3	Cost-Effective	1
4	Size	3
5	Interactivity	3
6	Safety	5
7	Mobility	4
8	Versatility	3
9	Power	5

Table 1: Design Considerations. The survey results allowed us to narrow down our customer's needs and quantify their importance to the overall success of the project.

Metric	Unit	Importance	Range Specification	Target Specification
Display	Inches	2	7-10	10
Power Output	W	5	4.63-18.5	13.9
Cost	USD	1	200-1000	200
Longevity	Year	4	0-5	3
Weather Proof	y/n	4	y/n	y
User Friendliness	y/n	3	y/n	y

Table 2: Metrics used to establish the design parameters.

<i>Quality Function Deployment</i>		Metric:	Display	Power Output	Cost	Longevity	Weather Proof	User Friendliness
	Needs:	Units:	Inches	W	USD	years	y/n	y/n
1	Reliability			•		•	•	
2	Efficiency			•	•	•		
3	Cost-Effective				•	•		•
4	Size							•
5	Interactivity		•					•
6	Safety					•	•	
7	Mobility							•
8	Versatility		•	•				•
Marginal Specifications:			7	13.9	1000	3	y	y
Target Specifications:			10	18.5	500	5	y	y

Table 3: Quality Function Deployment chart is used to quantify and relate different metrics to one another.

Application

A USB charging station for a tablet was selected since it does not require a large amount of power, it is convenient, and is relatively simple to build. This application was chosen because a standard cell phone charger outputs 5.0V and 750mA to charge the cell phone. From trials done on a Motorola Droid Razr Maxx, it is viewed that our system will need to be able to charge the tablet at about half the rate that it discharges, as shown in Figure 1. The tablet is interactive and the charging station can be utilized by everyone with a smart phone. The charging station and display would be built near the north entrance of the building since many visitors congregate at lounge near the north entrance of the CMU engineering building.

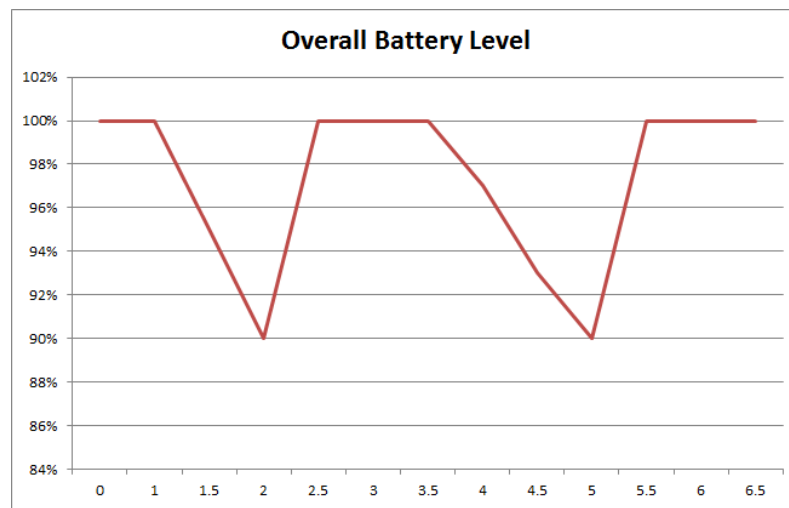

Figure 1: Charging and discharging of a Motorola Droid Razr Maxx. The battery level is on the vertical axis and number of hours on the horizontal.

Power Generation Concepts

Three power generation concepts were considered for this project. The first option was a large solar panel. Solar panels can be built from individual solar cells and scaled up to conform to the required application's power requirements. The panel would have been built by wiring thirty six 0.55W, 1000 mA solar cells in series to produce, which could potentially provide 19.8W peak power during the summer. During the winter it was estimated that the power would only provide around 0.8 W or 4% efficiency. Each cell is $3\frac{1}{8}$ " x $1\frac{5}{8}$ ", which when wired together would produce a panel that is 14" by 16", with spaces between the cells. The cells would then need to be attached to a frame and enclosed in either Plexiglass or a commercial solar cell epoxy. However, the solar panel needed to be southward facing and tilted at a 44 degree angle for the most effective static positioning. A suitable location near the northern entrance of the engineering building could not be found to produce enough power for our application.

The two other design concepts utilized the mechanical power produced by opening and closing a door. A geared track system was designed to generate power from each door swing. A small electric generator was mounted on the door, and a geared track was connected from the door frame to the generator. A rack and pinion system was used to convert the linear motion of the door opening to rotate the generator's rotor. This was not feasible as the generator could not sustain enough power from a single door swing to operate the system.

The geared track system could not produce enough power from a single door swing to power the system in any meaningful way. This observation led to the final design which kinetically saves the energy from each door swing using a hanging mass. Rather than each door swing turning a generator, each swing lifts a 6kg mass 20cm which is on a ratcheted axle. The axle is connected to the door through a small engine recoil starter, the cable of which is attached to the door. After five door swings the mass falls, turning the generator's rotor which is coupled with the mass' axle. The fall speed is controlled using an axle damper. At optimal speeds the generator produces 750mA at 5.5V.

Power Conditioning

A block diagram of the system is shown in Figure 2 to demonstrate how the short pulses of energy produced by the mechanical generator will eventually power a USB charging station. Switching converters were required to manipulate the energy produced by the mechanical generator into the desired voltage needed to charge the system's 3.6 V, 5000 mAh nickel metal hydride battery pack. While the current may fluctuate, the steady voltage will at least ensure that power is being delivered to the battery. The DC-DC converter topology used in the power generation module was a buck converter, and the application side power converter is a boost converter.

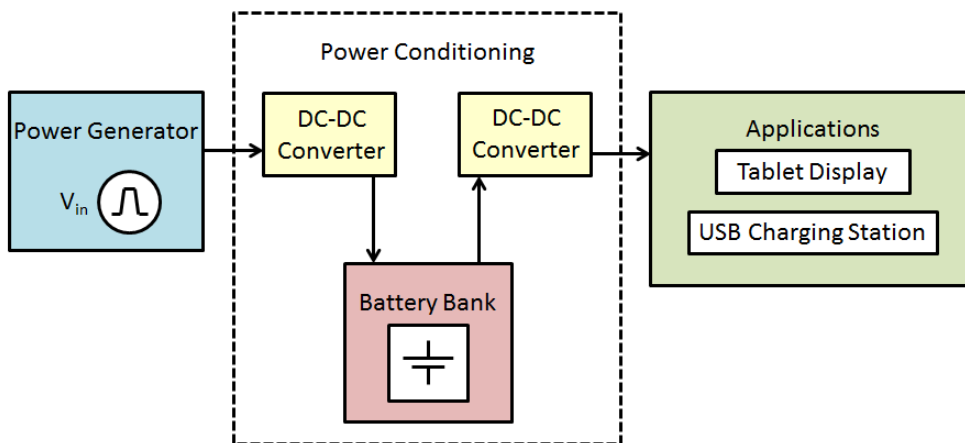

Figure 2. Block diagram of the system describing where each DCDC converter is connected and how the energy is stored.

With both the battery bank and application determined, the application side power converter topology needed to be a boost converter since the battery voltage is lower than the required USB voltage. A boost converter is a switching power pole converter implemented using a MOSFET, diode, PWM step-up controller, inductor, and capacitor. An example circuit is shown in Figure 3. Together the transistor and diode act like a bidirectional switch that regulates the current to the output. When the transistor is on, the inductor stores magnetic energy, and energy that is already stored in the capacitor is transferred to the output. When the transistor is off, the inductor and input voltage will appear to be two voltage sources in series, which increases the voltage across the capacitor and output to above that of the original input. Again, when the transistor turns on, the capacitor will discharge current, keeping the voltage across the output relatively constant, and the inductor will begin to charge again. The PWM step up controller, modeled as the voltage pulse V3 in Figure 3, is a Texas Instruments current controlled switching regulator IC [7], which tracks the output to create a closed loop feedback controller that runs the switching transistor.

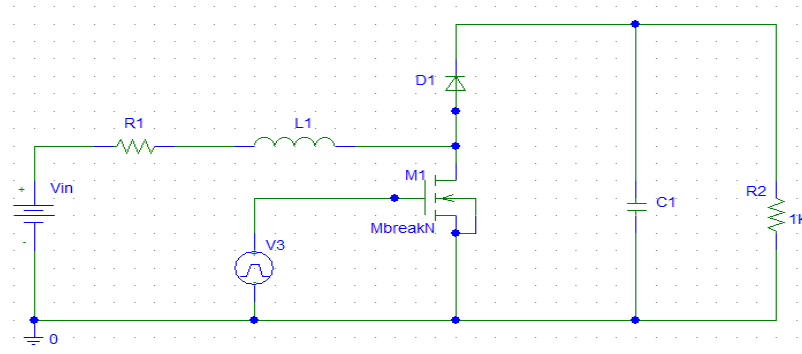

Figure 3. An example of a DCDC switching power pole boost converter.

The power converter topology used for the power generation module is a buck-boost switching converter. An example of a buck boost converter is shown in Figure 4. The buck-boost converter is built using the same materials as the boost converter. While the transistor is turned on, the current from the source increases the energy stored in the inductor, and the capacitor discharges current through the output. When the transistor is off, the inductor's stored energy is released to the output load and the capacitor. The duty cycle of the converter is controlled using the same TI MC33063 PWM IC as the boost converter, modeled as a voltage pulse V3 in Figure 4. When the duty cycle of the transistor is less than 0.5, the current in the inductor and the current in the capacitor effectively take turns sending current through the load, which results in an inverter output voltage that is less than the input voltage.

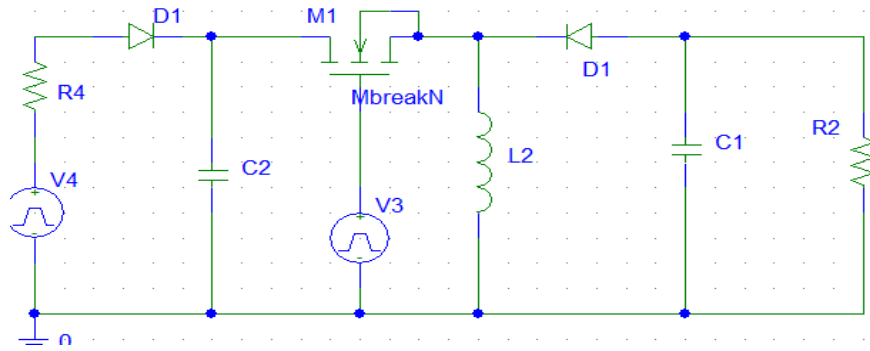

Figure 4. An example of a DCDC buck-boost switching power pole converter.

Conclusion

The mechanical power generator produces a short pulse of power which can be modeled as a square wave with amplitude of 5.5 V and a duty cycle of 0.015 with a 15 second period. This short pulse of power produces 5.54 J of energy per cycle, which is quickly captured with a by the input of the buck-boost converter. The voltage is then dropped down to a constant 3.6 V by the converter circuit, and the current flows to charge the battery pack. The battery, which is a constant voltage source at 3.6 V, is wired to the input of the boost converter circuit jumps the voltage from 3.6V to a steady 5.0V, which is connected to the output of the system, a universal USB port. From that port users can operate their mobile devices or use the system's tablet.

The proposed sustainable energy system consists of three modules: the power generator, the power storage, and the application. A door-powered generator was built to capture work done by people opening the doors to the engineering building. Power converters and a battery pack were used to condition the power into a usable form. A tablet and cell phone charging station was built as a way of making use of the captured energy. The purpose of this system is to promote the use of sustainable energy by providing a free service to visitors in the engineering building, as well as showcasing how much electrical power that can be generated simply by a person opening a door.

References

- [1] Solar Cell Roofing. Updated May 13 2013. Retrieved from <http://www.solarcellideas.com/2013/05/solar-cell-roofing.html>.
- [2] "Michigan Utility Scale Wind Farms 2012-2013". http://www.michigan.gov/documents/mpsc/wind_farm_summary_407660_7.pdf
- [3] K-Tor Press Release. "K-tor releases power box pedal power generator." September 2, 2013. Retrieved from <http://www.k-tor.com/k-tor-releases-power-box-pedal-power-generator/>

- [4] Guigon R., Chaillout J., Jager T and Despesse G. "Harvesting raindrop energy: experimental study." Smart Mater. Struct. 17. February 2008.
- [5] Edam, B. "Boon edam introduces the world's first energy generating revolving door." July 11, 2008. Retrieved from <http://www.boonedam.us/press/pressdetail.asp?PressId=182>
- [6] "1.5A Peak Boost/Buck/Inverting Switching Regulators" January 2011. Datasheet <http://www.ti.com/lit/ds/symlink/mc33063a.pdf>