

Optical Sensor Development

Kyle Smith and Dr. Tolga Kaya

Department of Engineering and Technology

Central Michigan University

Mount Pleasant, MI 48858

Email: {smith5ks, kaya2t}@cmich.edu

Abstract

Through the development of a sweat-sensing patch, the need for improved detection and prevention of dehydration will be addressed. Functionally, the sweat-sensing patch must evaluate the concentration of sweat. A proprietary technique has been developed at Central Michigan University to use ultraviolet-visible light spectroscopy to determine the salt concentration of sweat. Lawsone, a dye used in Henna tattoos, is added to sweat and the chemical reaction results in a change in color. The color, detected by ultraviolet-visible light spectroscopy, is dependent upon the salt concentration in the sweat. At this point, the ultraviolet-visible spectrometer has been used to test solutions with known salt concentrations. The results have proven that ultraviolet-visible spectroscopy is a reliable method of determining the salt concentration of sweat. An optical sensor is being developed to perform the same function as the ultraviolet-visible light spectrophotometer.

The optical sensing circuit consists an operational amplifier, an LED, and a photodiode. The LED light source shines through a solution and is received by a photodiode. An analog circuit was developed and tested, proving that the optical sensor is capable of detecting a change in color. This change in color will correspond to a particular salt concentration. In order to measure the precision of the digital optical sensing circuit, identical sweat samples will be tested using the optical sensor and the ultraviolet-visible spectrometer. Thus, similar absorption measurements by the optical sensor and the ultraviolet-visible spectrometer will indicate that the optical sensor can precisely determine the salt concentration in sweat. The dehydration sweat sensor being developed in this project would revolutionize dehydration detection.

I. Introduction

In the heat of battle, the heart pounds, pupils dilate, and perspiration increases. All the while, the situation demands that performance and decision-making function at optimal levels. One cannot afford to be blindsided by dehydration. Associated with dry skin, headaches, thirst, and dizziness, dehydration is a significant risk for soldiers and athletes enduring extreme conditions. The risk of dehydration caused by excessive sweating can be exacerbated by hot, humid weather and strenuous activity. If detected early, dehydration can be remedied through increased fluid consumption and electrolyte replenishment. When not treated appropriately, however, dehydration can lead to such complications as seizures, kidney failure, coma, and even death [1]. Often difficult to detect, dehydration remains an ever-present hazard for athletes and

soldiers in high-pressure situations. Currently, trainers, coaches, and commanding officers rely primarily on observation of physical symptoms for dehydration detection. More accurate detection, including determining the degree of dehydration, requires blood tests or urinalysis, which are usually impractical during competition or battle [1]. As a result, there is a strong need for precise real-time detection of dehydration. Determining the level of dehydration will require analysis of electrolyte concentration of the sweat.

A proprietary technique to determine electrolyte concentration is being developed at Central Michigan University. This technique involves the use of an ultraviolet-visible light spectrophotometer. Ultraviolet-visible light spectroscopy is a technique used in chemistry to evaluate the composition of various solutions. Essentially, an ultraviolet light source and a visible light source are both sent through a reference solution and a sample solution. The absorption level of the reference is subtracted from the absorption level of the sample [3]. The resulting absorption is plotted against the wavelength of the light source in order to analyze the composition of the sample solution. Since the sweat is generally a clear solution, the absorption level will not vary significantly regardless of salt concentration. As a result, a dye must be added to the sweat before its composition can be analyzed. Lawsone, a dye known for its use in Henna tattoos, was determined to be appropriate for this particular application. An evaluation of the chemical structure of Lawsone, revealed a single OH bond [2]. This bond enables Lawsone to interact with the salt in sweat to form different structures depending upon the concentration of the salt. These new structures will impact the levels of absorption. In addition to the OH bond, Lawsone is a non-toxic dye and is therefore safe for contact with skin [2]. To date, this project has included experimentation with Lawsone that has revealed favorable absorption characteristics.

The size of the ultra-violet light spectrophotometer makes it impractical for use outside of the laboratory. In an attempt to miniaturize and mobilize visible-light spectroscopy, an optical sensing circuit is being developed. An optical sensor will utilize an LED shining through the channel of sweat. The level of absorption will be calculated and used to determine the electrolyte concentration of the sweat. Ultimately, the optical sensor will ultimately be placed on a patch to be worn by soldiers and performance athletes. The patch will be small enough to wear on one's arm and will send an individual's dehydration levels wirelessly to the appropriate medical personnel. Real-time communication of dehydration levels to the appropriate medical personnel will transform dehydration treatment. In addition to the absence of real-time dehydration detection on the market, preliminary discussions with Central Michigan University's athletic trainers and ROTC program have indicated that this project could yield a highly marketable device.

II. Circuit Design

An optical sensor is being designed to perform a function similar to ultraviolet-visible spectroscopy. Lawsone, through early experimentation, appears to have peaks of absorption when the light source has a wavelength between 400 nm and 500 nm. As such, the optical sensor can be developed with only one light source that has a wavelength within this range. This one light source will be a blue LED emitter, which has a wavelength of approximately 450 nm. The blue LED emitter shines through the sweat channel to a photodiode. The signal received by the

photodiode is converted from a current to a voltage using an operational amplifier. The circuit schematic is provided below in Figure 1.

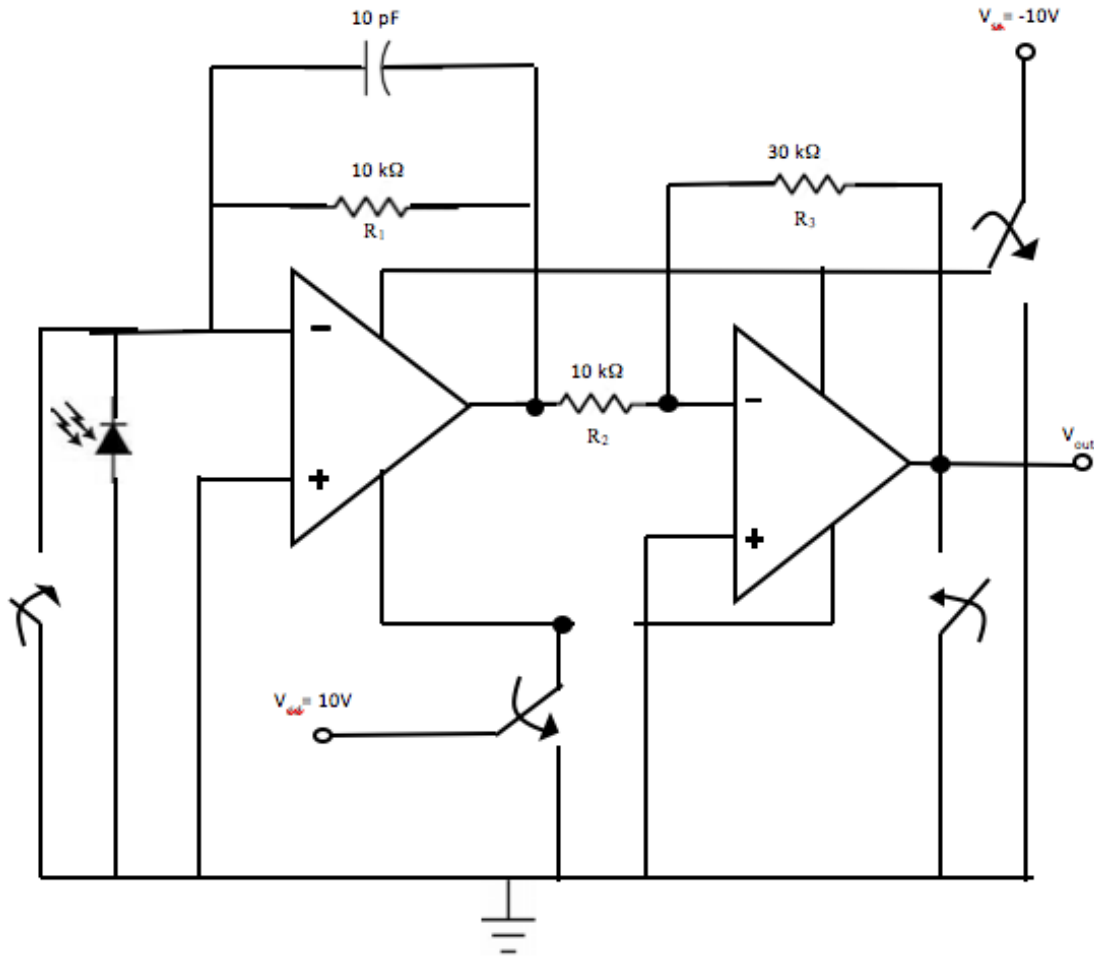

Figure 1: Circuit schematic for the optical sensing circuit.

When light was applied to the photodiode in the Central Michigan University electronics laboratory, a current resulted. Ultimately, a microcontroller will be used to interpret and communicate the signal from the optical sensing circuit. In order to make the circuit compatible with the analog to digital conversion function of the microcontroller, the output signal of the circuit must be a voltage. As such, a current to voltage converter must be inserted into the circuit after the photodiode. An operational amplifier is used to construct the current to voltage converter. Theoretically, the output voltage of the converter should be equal to the input current multiplied by the feedback resistance. In Figure 1, resistor R_1 , serves as the feedback resistor. In order to observe the behavior of the current to voltage converter, the output voltage was measured as the feedback resistance varied.

A white light bulb was applied to the photodiode for the preliminary current to voltage converter experiment to ensure that all wavelengths were included. Expecting a proportional change in the output voltage, the feedback resistance was varied. After a few trials, it appeared as

though stability of the circuit was the main concern. As demonstrated by the results in Table 1, the output voltage experienced minimal increases once the feedback resistances was increased past 10 k Ω . When the feedback resistance was 100 Ω , the operational amplifier produced a minimal output voltage. At 1 k Ω , the feedback resistance was large enough to produce a significant current. The circuit was not stable, however, as the output voltage fluctuated significantly despite a constant photodiode exposure and a relatively constant current. When a larger feedback resistance of 10 k Ω was applied, the circuit achieved stability and the largest voltage range of the trials. Given these results, it was deemed that the feedback resistance of 1 k Ω was not large enough in comparison to the impedance of the photodiode. The output voltage range decreased as the feedback resistance was increased past 10 k Ω .

Table 1: Output Voltages with One Operational Amplifier (White Light Bulb)

R ₁ Value (Ω)	Output Voltage With No Light Applied (V)	Output Voltage With Fully Concentrated Light (V)
100	0	0.0366
1 k	0	-1.4521
10 k	0	-4.274
20 k	0.1013	-4.021
30 k	0.4220	-4.304
50 k	0.5010	-4.296
100 k	1.345	-4.650

Based on this information and the results from the table, the value for R₁ was chosen to be 10 k Ω . It is ideal for the output voltage to be zero when there is no light applied to the photodiode. Even a minor alteration in voltage reflects a change in color and therefore, a change in electrolyte concentration. Such an alteration can result from even the slightest amount of external light. As such, it is imperative for the optical sensing circuit to be insensitive to external light. Insensitivity to external light is demonstrated by a circuit producing no output voltage when no direct light is applied. It is worth noting that the same method was used to cover the photodiode in all of the trials. This allows for a true comparison to be made for all of the feedback resistances used in the experiment. Understanding that a small change in the output voltage could indicate a significant change in the electrolyte concentration of sweat, an operational amplifier was included in the circuit to amplify the output voltage from the current to voltage converter. The amplifier was chosen to be an inverting amplifier since the output voltage of the current to voltage converter is negative. In attempt to provide consistency for the circuit, all of the resistances were chosen to be the same order. Thus, R₂ was chosen to be 10 k Ω and R₃ was chosen to be 30 k Ω . This amplified the circuit by a factor of three and inverted the signal.

III. Analog Circuit

The circuit design presented in Figure 1 is an analog circuit, meaning that the output signal is continuously variable. Ultimately, the circuit used in the final dehydration detection

patch will be a digital circuit. As such, the analog circuit served essentially as proof of concept. The primary goal of the analog circuit was to determine the color of a particular solution. While a blue LED light source will be the light source of the final circuit, a green laser was used during preliminary testing of the analog circuit. A solution was placed in a plastic cuvette with a square base of approximately 12 mm. The solution consisted of water mixed with a few drops of food coloring. The goal of the experiment was to determine which food color was added to the water. The green laser was shone through the solution. On the other side of the solution were the photodiode and the rest of the optical sensing circuit. An illustration of the experimental procedure is presented in Figure 2.

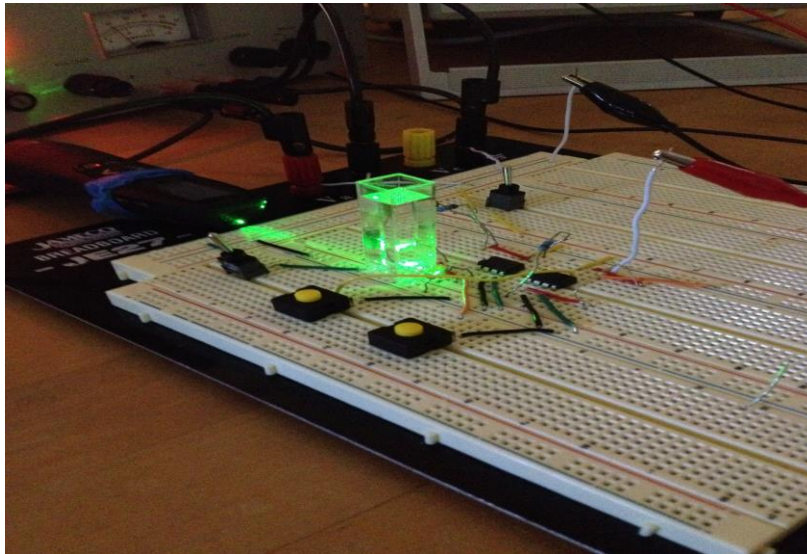

Figure 2: The experimental design for the analog circuit.

Preliminary tests were conducted to determine the baseline output voltages. For each color, the output voltages were recording for varying number of drops of food coloring. Using the baseline voltages, the output voltages were predicted for known quantities of food coloring added to the solution. The output voltages were accurately predicted within 0.08 V. Based upon this, it appears as though the optical sensing circuit will detect even the slightest change in color. This makes the circuit sensitive to electrolyte concentration variation in the sample solution. Having essentially proven the concept, the next step is to develop a digital optical sensing circuit.

IV. Digital Circuit

While the analog circuit is capable of detecting slight changes in color, it lacks the ability to communicate the results. Potential applications in performance athletics and the military, makes it imperative that the circuit to have the ability to communicate the results. Thus, a digital circuit is being developed using a PIC16F1823 microcontroller. The analog to digital conversion (ADC) function of the microcontroller will translate the analog voltage provided by the current to voltage converter into a digital signal. The digital signal can be amplified, eliminating the need for the second operational amplifier. Additionally, the microcontroller will send the voltage signal to a computer, where it will be manipulated to find the absorption level. The use of a

microcontroller allows the absorption level to be measured and saved both before sweat is flowed through the channel and while sweat is in the channel. This provides a reference and a sample absorption level. With both a reference and a sample absorption level, the results from the optical sensor can be compared to the absorption levels determined using the ultraviolet-visible spectrometer.

A program is being developed for the microcontroller to utilize the ADC function. At this point, the program has been successfully tested using solutions of different colors. Communication with the computer was accomplished through the hardwiring of a UART cable. Ultimately, the communication between the computer and digital circuit must occur wirelessly in order to it to be utilized by the military and professional athletes. For simplicity, the minimum viable product will display the output on an LCD. As such, the functionality of the device can be demonstrated without external hardware. The functionality of the digital circuit will be tested further using solutions containing Lawsone and sweat. The results will be compared to those obtained using the ultra-violet light spectrophotometer. As mentioned previously, if the digital circuit produces results that match the results obtained using the ultra-violet light spectrophotometer, the functionality of the digital circuit is verified and the minimum viable product can enter the final stages of development.

V. Summary & Conclusion

Dehydration is an ever-present threat, especially for athletes and military personnel operating in extreme conditions. Constantly under duress, soldiers and athletes cannot afford to be blindsided by dehydration and its accompanying risk factors. Chasing the allusive “edge,” athletes and military personnel scour the markets for performance enhancement aides. What is absent from the market, however, is adequate dehydration detection and prevention technology. This project aims to harness the proprietary technique developed at Central Michigan University to determine the salt concentration of sweat. In order for practical application on battlefields and playing surfaces, a circuit was developed to perform ultraviolet-visible light spectroscopy on a smaller scale. Acting as an optical sensor, the circuit uses a photodiode to determine the absorption level of a particular solution. The absorption level corresponds to a salt concentration and thus, an individual’s dehydration level. For proof of concept, the optical sensor was designed using an analog circuit.

Capable of detecting a change in color, the analog circuit verified that ultraviolet-visible light spectroscopy could be performed using an optical sensor. It did not, however, possess the capability to communicate with a computer. Applications in the military and performance athletics demand that the dehydration detection device be compatible with a computer interface and thus, a digital circuit was developed. Currently, the digital circuit has been tested using solutions of varying colors. Accurately detecting these colors, the digital circuit has been wired to the computer using a UART cable. Having completed preliminary testing, the digital circuit will be testing using solutions consisting of sweat and Lawsone. Functionality will be verified if the digital circuit produces results that match the results of the ultraviolet-visible light spectrophotometer.

Assuming that the functionality will be verified, the digital circuit will be incorporated into a minimum viable product for commercialization. At this point, testing of the optical sensor has proven that ultraviolet-visible light spectroscopy can be accomplished on a smaller scale using an optical sensor. A microcontroller is necessary in order to provide both a reference and a sample absorption level. As such, the digital circuit design most nearly replicates the ultraviolet-visible light spectrophotometer. While the ultraviolet-visible light spectrophotometer delivers greater precision, the optical sensor proves to be a more practical solution for applications in which time and convenience are critical. The optical sensor will be incorporated into a wearable patch or band, resulting in a user-friendly device that provides an unmatched real-time dehydration feedback. Therefore, it is extremely marketable to military personnel and performance athletes.

VI. Bibliography

- [1] "Dehydration." *Mayo Clinic*. Mayo Foundation for Medical Education and Research, 07 Jan. 2011. Web. 2 Sept. 2013.
- [2] "Lawson." *ChemSpider*. Royal Society of Chemistry, 2013. Web. 04 Sept. 2013.
- [3] Reusch, William. "Visible and Ultraviolet Spectroscopy." *Introduction to Spectroscopy*. Michigan State University, 05 May 2013. Web. 10 Sept. 2013.