

# Design, Implementation, and Dynamic Behavior of a Power Plant Model

M.M. A. Rahman, Member ASEE  
Grand Valley State University  
Grand Rapids, MI  
[rahmana@gvsu.edu](mailto:rahmana@gvsu.edu)

Daniel Mutuku  
Consumers Energy  
West Olive, MI  
[Daniel.Mutuku@cmsenergy.com](mailto:Daniel.Mutuku@cmsenergy.com)

## Abstract

This paper presents a power plant model to study its dynamic behaviors in lab environment. Synchronous generators are the most common type of generators in power plants for supplying power to large power systems. Experimental analysis of a commissioned generator can be expensive and creates safety risks due to high voltages and currents involved. Having a reduced scale model of the generator for experimental purposes can mitigate cost and safety concerns. Additionally, a reduced scale model can be used for educational purposes. In this project, a small scale power plant model is proposed and implemented along with experimental analysis of the generator. The implemented model has a motor as the prime mover, a synchronous generator, a static exciter, and a variable resistive, inductive and capacitive load. The control system of the model plant is implemented using a Programmable Logic Controller (PLC) with a Human Machine Interface (HMI). Using the implemented model, the dynamic behavior of the generator under different load conditions was investigated. Results from experimental studies are presented in this paper. This industry sponsored model power plant, a university-industry collaboration project between GVSU and Consumers Energy, can be used for power engineering education for students and practicing engineers in future as discussed later in Section 6.

## 1. Introduction

Electric generators are at the heart of power systems and an important topic in power engineering. The electrical energy produced by generators is transmitted to customer loads which can be inductive, capacitive, resistive, or a combination of these three. Generators at the power plant can vary from a few MW to hundreds of MW. Experimental analysis of these generators can be expensive and sometimes dangerous. Having a power plant model that can be used for laboratory experimental studies and educational purposes can be beneficial. In this project, a small scale power plant model with one generator is implemented along with analysis of the dynamic behavior of the generator. The implemented model consists of a motor coupled to a three phase synchronous generator, an excitation system for the generator, and a voltage regulation system. A control system was also designed and implemented to integrate the different components of the model and interface with the user. Electrical energy from the generator powered a variable resistive, inductive, and capacitive load. Using the model the dynamic behavior of the generator under different loads was studied and is explained in this paper.

## 2. Background study and literature Review

### 2.1 Synchronous Generators

Synchronous machines are the most popular source of mechanical energy to electrical energy converters in power engineering world<sup>1</sup>. They can be used as a motor, a generator or as a

synchronous condenser. The operation of synchronous machines as a generator is the only operation that was considered in this project. Synchronous generators consist of windings in the rotor (field windings) and the stator (armature windings). The rotor is rotated by a prime mover while a direct current (DC) called the field current,  $I_F$  is applied to the field windings. This results in a rotating magnetic field that induces a voltage on the stator windings according to Faraday's Law of induction. The process of applying a field current is called excitation.

## 2.2 Synchronous generator load characteristics

The dynamic behavior of the synchronous generator under load depends on whether (1) generator is operating alone powering an isolated load (island operation) or (2) generator is operating in parallel with other generators on an infinite bus. In this study a generator under island operation as shown in Figure 1 is considered. The behavior of a synchronous generator under load varies depending on the power factor of the connected load.

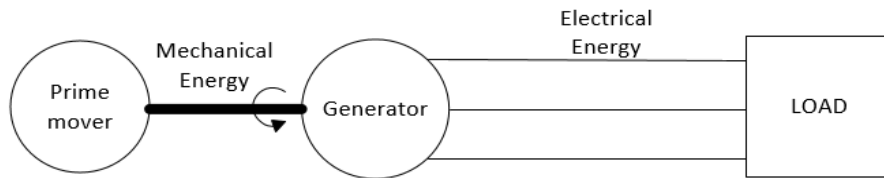

Figure 1: The representation of a synchronous generator operating alone

The behavior of the synchronous generator operating alone under load can be summarized as: (1) adding resistive load will reduce the terminal voltage of generator<sup>3</sup>, (2) adding inductive load significantly reduces the terminal voltage<sup>3</sup>, and (3) the effect of capacitive load (leading power factor load) depends on the total system reactance. If the total reactance of the system is negative ( $|X_S| < |X_C|$ , current leads generated voltage) then adding additional capacitive load can actually increase the terminal voltage. If the total system reactance is positive ( $|X_S| > |X_C|$ ; current lags generated voltage), then adding additional load reduces the terminal voltage<sup>3</sup>. It is desirable to keep the voltage supplied to a load constant despite varying customer loads. This can be done by controlling the induced voltage,  $E_A$  as the load changes which is done automatically using an automatic voltage regulator (AVR)

## 2.3 Automatic Voltage Regulator (AVR)

The main function of the AVR is to control and maintain the terminal voltage of the generator by adjusting the generator exciter voltage<sup>4</sup>. Inputs to the AVR are the desired terminal voltage setpoint, generator terminal voltage and line current, and the output is a control signal that controls the excitation voltage. The AVR can be digital or analog; digital AVR (DAVR) is more flexible, easy to implement and costs less compared to analog AVR<sup>3,4</sup>. Although, there are various control methods studied for excitation systems, the general Proportional-Integral-Derivative (PID) control method is mostly used in AVRs due to its easy approach<sup>4</sup>. Figure 2 shows a simplified block diagram for an AVR that uses a PID controller.

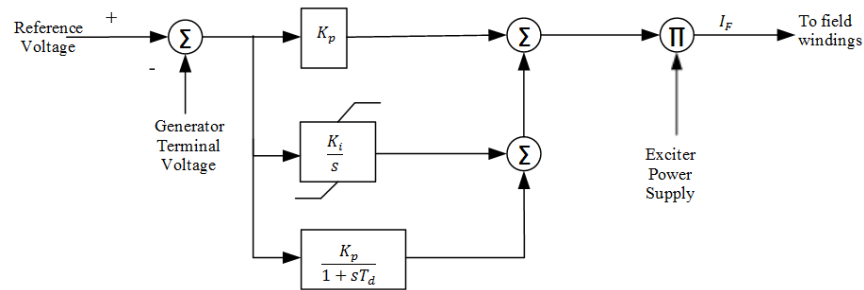

Figure 2: A simplified block diagram of AVR that uses PID control

## 2.4 Frequency and power control

It is desired that the frequency of voltage supplied by the generator remain constant or vary in a limited and controlled manner when active/real and reactive power loads are connected. Real power flow is related to the prime movers energy input, and thus to the speed of the synchronous generator while reactive power is related to the terminal voltage<sup>5</sup>. A speed governor is used to ensure that the speed of the prime mover is relatively constant despite changes in real power load on the generator. The speed governor monitors the speed of the turbine using the speed sensor and opens or closes the fuel control valve to maintain a set-point speed.

## 3. Methodology

To implement the proposed power plant model a synchronous generator coupled to an induction motor was used. The induction motor will provide the mechanical power to the generator and will be controlled using a variable frequency drive (VFD) as the speed governor. Advances in power electronics and digital signal processing have resulted to VFDs that can control induction motors to precise speeds irrespective of load. The proposed model is shown in Figure 3 where VFD is a Variable Frequency Drive, IM is an induction motor, SG is a synchronous generator, PLC is Programmable Logic Controller, HMI is Human Machine Interface, and RLC are resistive, inductive and capacitive loads, respectively.

## 4. Implementation

The proposed model was implemented as shown in the picture of Figure 5. A 1/2 HP, 208-240 V 3-phase, 60 Hz, 1750 RPM, induction motor was used to drive a synchronous generator. The motor was controlled using a single phase Power-Flex 525 AC Drive VFD made by Allen-Bradley, the VFD was powered by 220 V single phase and was rated for 0.75 kW/1 HP. The VFD was controlled over Ethernet IP communication from a PLC. The motor was coupled to a 0.3 kW 60 Hz, 1800 RPM three-phase Salient pole synchronous generator. A static exciter was designed using 120VAC as the input power, a step-down transformer, full wave rectifier and a DC –DC Type-A chopper that controlled the field current using a PID controller. The circuit for the exciter is shown in Figure 5. To have closed loop control, the exciter field current was sensed using a DC current transducer and fed back to the PLC as shown in Figure 5. The exciter PLC was also fed with the following generator information from the 3-phase multifunctional meter: phase current, phase voltage, power factor, frequency, watts, VAR, and volt-amperes. Control of the system was implemented using a Compact Logix L32E PLC made by Allen Bradley. This PLC interfaced with the exciter PLC, VFD, and an Allen-Bradley 1700P industrial touchscreen

computer which was used as an HMI. The interface was done over Ethernet IP communication protocol.

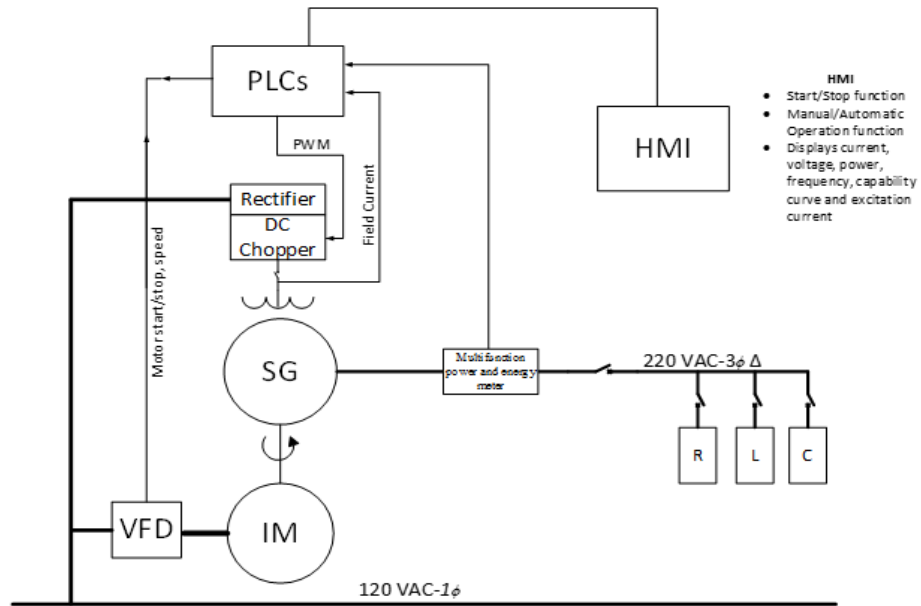

Figure 3: Block diagram of proposed model power plant

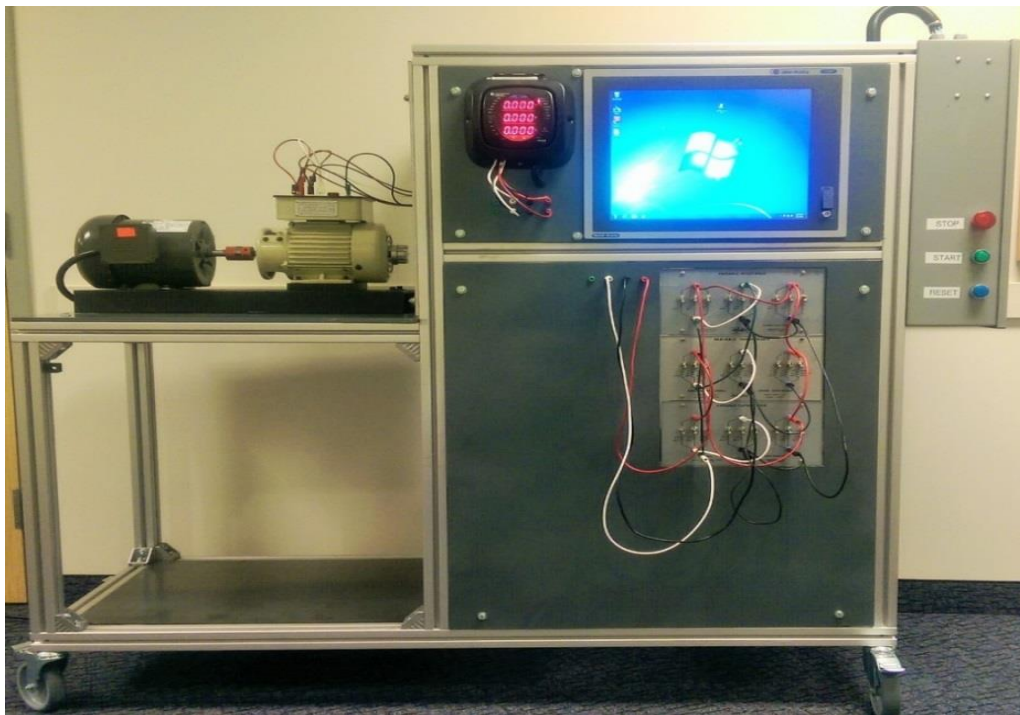

Figure 4: The power plant model that was implemented

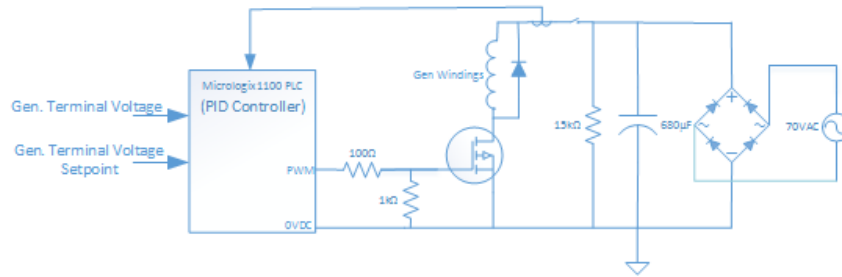

Figure 5: The implemented static exciter circuit

## 5. Experimental results

Using the implemented model, the dynamic behaviors, an important power engineering topic, of the generator under different load conditions were studied and compared to the expected behavior. The generator speed was set to 1800 rpm resulting in a frequency of 60 Hz and excited to the rated voltage of 220 V for a delta connected load. The PID controller was tuned and different loads were connected to the generator while (i) excitation was held constant and (ii) excitation current was controlled by the AVR.

### 5.1 Unity power factor load

With the generator in manual mode, the field current was adjusted to have 220 V terminal voltage and a 1200  $\Omega$  load was connected on each phase. The field current was held constant and Figure 6 shows that the terminal voltage decreased as expected when a resistive load was connected. Then the generator was stopped and switched to automatic mode. The voltage was



Figure 6: Unity power factor load with constant field current (manual mode)

set at 220 V and a 1200  $\Omega$  load connected on each phase. With the generator in automatic mode, the AVR worked to maintain the set-point voltage. As expected the generator terminal voltage reduced from 220 V to 202 V before the AVR was able to compensate for the drop in voltage by increasing field current. The AVR increased the field current from approximately 275 mA to 305 mA as shown in Figure 7. The AVR was able to restore the voltage back to 220 V in less than 10 seconds.



Figure 1: Unity power factor load with AVR (automatic mode)

### 5.2 Lagging power factor load

In manual mode, the excitation current adjusted to have the terminal voltage at 220 V. A 3.2 mH load was connected on each phase with field current held constant and the voltage dropped from 220 V to 170 V as shown in Figure 8. After some time, an additional 1.6 mH load was added in parallel with the 3.2 mH on each phase and terminal voltage decreased to 110 VAC. This was as expected since adding a lagging power factor load significantly reduces the terminal voltage if the field current is held constant. Then the generator was switched to automatic mode to have the AVR controlling the field current. With the generator operating at 220 V, a 3.2 mH load connected on each phase. This dropped the voltage to approximately 175 V but the AVR was able to bring up the voltage back to 220 V in less than 12 seconds by increasing the field current from 275 mA to 390 mA as shown in Figure 8.

### 5.3 Leading power factor load

In manual mode, a leading power factor load of 2.2  $\mu$ F was connected on each phase. The field current was held constant and the terminal voltage increased from 220 V to 250 V as shown in



Figure 8: Lagging power factor load with the field current held constant (manual mode)



Figure 9: Lagging power factor load with AVR (automatic mode)

Figure 10. This was expected since the total system reactance was more capacitive. Figure 11 shows the effect of loading the generator with a leading PF load while the field current was being controlled by the AVR. When the load was connected the terminal voltage increased. However,

the AVR was able to bring down the voltage to 220 V in less than 12 seconds. The AVR did so by reducing the field current from 275 mA to 170 mA.



Figure 10: Leading power factor load with the field current held constant (manual mode)

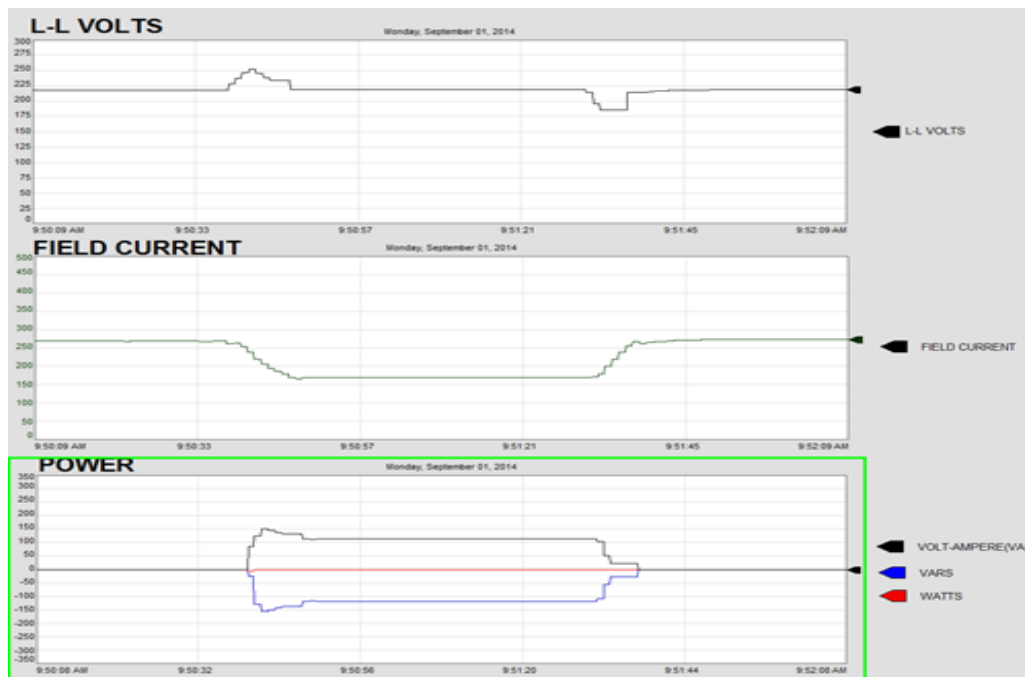

Figure 11: Leading power factor load with AVR (automatic mode)

### 5.4 RLC load

The effect of loading the generator with an RLC load was studied. The generator was put in manual mode then the field current adjusted to have the terminal voltage at 180 V. The generator was loaded with 1200  $\Omega$ , 3.2 mH and 2.2  $\mu\text{F}$  loads in parallel on each phase. Figure 12 shows



how the terminal voltage changed. As expected, the resistive load reduced the terminal voltage from 180 V to 130 V, and the inductive load further reduced the voltage to 113 V as shown in Figure 12. When the capacitive load was added the terminal voltage climbed from 113 V to 190 V. With automatic mode to have the AVR controlling the field current when a resistive, inductive and capacitive loads were added, the AVR was able to maintain the set-point terminal voltage of 180 V as shown in Figure 13. The AVR increased field current when the resistive load was added, further increased field current when an inductive load was added and reduced field current when the capacitive load was added.

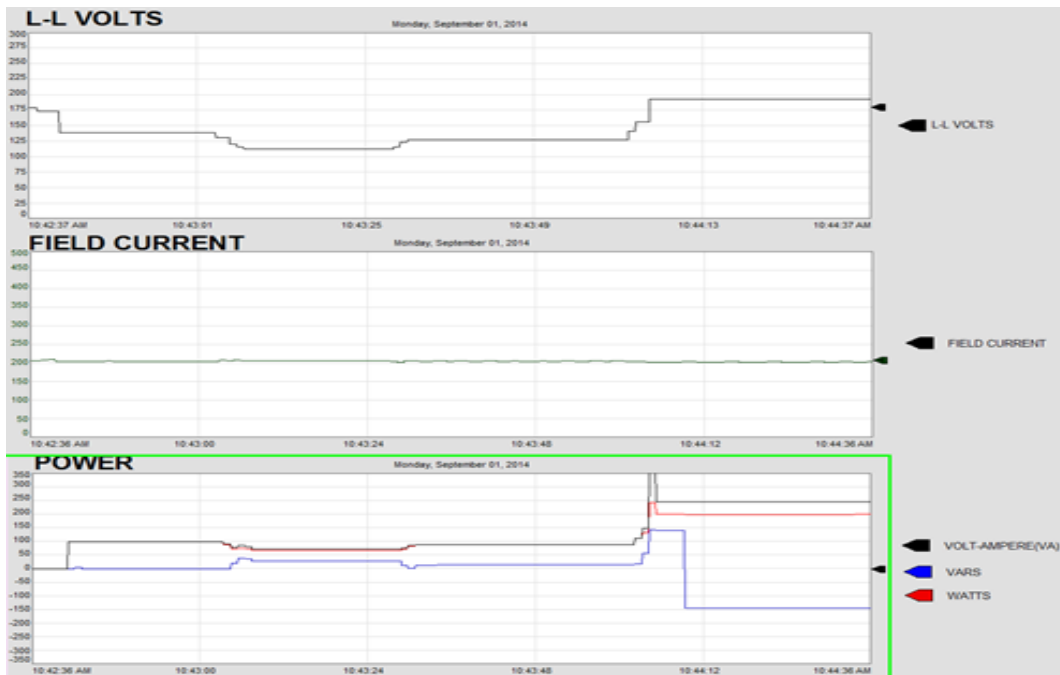

Figure12: RLC load with field current is held constant (manual mode)

## 6. Conclusions

This paper presented design, implementation, and experimentation; and proposes several educational applications of a power plant model. Dynamic behavior of a generator in island operation under different loads was investigated and compared to theoretical expectations and calculations. Theoretical results and measured results from the model indicated that when the synchronous generator responds to the power needs of the connected load. The study showed that a resistive load will reduce the terminal voltage, an inductive load will significantly reduce the terminal voltage, and a capacitive load will increase the terminal voltage if the total reactance of the generator and load is capacitive. To alleviate this effect, an AVR can be used to control the excitation current of the generator which maintained the terminal voltage constant. The model that was built can be expanded to add additional functionality subject to availability of more funding from Consumers Energy. Since the model was intended to be used for experimental studies and educational purposes, the future expansions could include: adding protective relays that can be used to study generator protection schemes, adding an additional motor-generator set, and studying synchronization features. Once implemented, this would enable the model plant to

be used in future for the following learning activities for students and practicing engineers: (1) Students will learn the basic operations and maintenance of real life power system in lab environment, (2) Students will learn about a practical example of PID controllers used in power systems and its characteristics, (3) Students will be able to study the application of power electronics in controlling voltage (supply for excitation field current) using a class-A DC-DC chopper, (4) Students will be able to perform load flow study practically rather than using just simulation program, (5) Students will be able to visualize effects of load changes on power system stability in lab environment. This study could be used as a substitute for visiting Consumers Energy load dispatch center usually done in summer for junior level students, and (6) Students will be able to learn synchronous generators' operation in parallel and their load sharing mechanism.



Figure 13: RLC load with AVR (automatic mode)

### Bibliography

- [1] Wildi, Theodore. *Electrical Machines, Drives and Power Systems*. 6th ed. Upper Saddle River: Pearson Practice Hall, 2006. 377-396
- [2] Boldea, Ion. *Synchronous Generators*. Hoboken: Taylor and Francis, 2010. Ebook Library. Web. 26 Mar. 2014.
- [3] "Stand Alone Phasor Diagrams." *Electrical Machines*. Ed. Andy Knight. University of Calgary, n.d. Web. 29 Mar. 2014. [http://people.ucalgary.ca/~aknigh/electrical\\_machines/synchronous/stand\\_alone/sa\\_phasors.html](http://people.ucalgary.ca/~aknigh/electrical_machines/synchronous/stand_alone/sa_phasors.html)
- [4] Farouk, N.; Tian Bingqi, "Application of self-tuning fuzzy PID controller on the AVR system," *Mechatronics and Automation (ICMA), 2012 International Conference on*, vol., no., pp.2510,2514, 5-8 Aug. 2012
- [5] Rushmore, David B.; Lof, Eric A., "Generator and prime mover capacities," *American Institute of Electrical Engineers, Proceedings of the*, vol.32, no.3, pp.709,720, March 1913 doi: 10.1109/PAIEE.1913.6661145