

Semi-Autonomous Gesture Controlled UAV Transportation System

Andrew Gigowski, Nicholas Martin, Timothy Root, Aaron Yoon,
Zihao Yuan, Zhiyu Zhou, Kumar Yelamarthi
Central Michigan University
Mt Pleasant, MI 48858
Email: k.yelamarthi@ieee.org

Abstract

This paper proposes a transportation system that will take a user's gesture input and transport an object accordingly. Unmanned Aerial Vehicle (UAV) transportation systems using perceptual computing can play a prominent role in many applications to simplify the job of transportation. Based on the gestures, the proposed system can send navigating signals to the UAV while viewing video feedback from the UAV. The system combines a perceptual computing camera feeding signals to a computer that are in turn sent to the UAV which will react to the signals to pick up the object and travel to a different location. Resulting from preliminary testing, the system will provide efficient communication between the subsystems involved in the project to transport an object once the entire system is combined.

Introduction

When the personal computer debuted the only input device available was the keyboard, and shortly after that came the mouse. These devices were limited in their ability to connect the user to the actions on the display. Then came the touch screen which allowed users to directly interact with the screen output which allowed a more personal interaction between the user and the computer. The industry is now developing the next generation of input devices, a more instinctive and natural way to interact with computers. Perceptual computing allows computers to perceive actions and motions of users. It allows the user to give intuitive commands that can control a multitude of functions given the right programming¹.

This paper proposes one way to realize the possibilities of perceptual computing. An intuitive way to control a real world object, in this case a quad-copter. UAVs have been around for a long time, but they have been limited to a single form of control input. The exciting new capabilities of perceptual computing will be used to make a more instinctive controller, the user. Using gesture input the operator can perform all of the same functions of a normal radio controller. With added hardware the user can receive video feedback from the transportation system that will allow for better obstacle avoidance than can be achieved by normal ground observation. These aspects coupled with a pickup design will create a robust transportation system that is able to perform a host of different tasks.

Previous Work

When it comes to aerial transportation systems using quad-copters is something that is getting more popular in today's society. One of the most popular in terms of package delivery or retrieval is the Matternet System. Another system to be considered is the Amazon drone. These systems are inhibited by poor controllability. These systems do not fall well into the scope of the current

project, but they are aerial transportation systems. They each have a different end goal than the project that is currently being worked on. There are many types of systems that are ground systems that have different kinds of navigation in them. One of these ground systems was developed at the University of Texas. It used a Microsoft Kinect sensor which is able to sense depth and color. In this project the focus was on its ability to sense different depths. The sensor detected the relative distance to objects. The user can effortlessly read the depth from the black and white images that are created on the screen. Darker areas are passable areas, while lighter objects are considered an obstruction².

Perceptual computing is an innovative technology that is just starting to make a large impression in the media. There are several companies that use this technology but the most established of these is the Microsoft's Kinect³. This device can understand the user's large motion gestures, such as arm motions or bending of the limbs. The distance the device can read from is about four to twelve feet. This can be extremely limiting if the user would want to use it on a laptop or tablet.

Two of the benchmarked systems are the Matternet and the Parrot AR.Drone 2.0. The Matternet is a system that is good for carrying small medical packages through short distances⁴. The AR.Drone 2.0 is a small lightweight quad-copter that cannot carry a load but is easily controlled⁵. These two systems combined would be the goal of this project; an easily controlled system that can carry a small load, though it would be controlled by using intuitive gestures.

Specifications

This system was designed to meet specifications that are essential for the successful operation and communication of all components of the design while exploiting the newly developed perceptual computing technology. As seen in Table 1 the attributes of the system are ranked in importance on a scale from 1 to 5 with 1 being the lowest and 5 being the greatest. The attributes given 4 or 5 will be given the highest importance while those given a value of 1 or 2 will be pursued with a lower priority. Some of these attributes were created to allow for comparison with other systems. For example, manual override is not directly related to this system, because the UAV is manually controlled. However, other systems are simply automated without the ability to override manually. Benchmarking other systems permitted a restriction of the specifications which narrowed the requirements of the system and gave some perspective on where the performance should lie within a specified range.

Table 1: System Attributes

Attribute #	System Attribute	Ranking
1	Obstacle Avoidance	5
2	Manual Override	5
3	Gesture Control	4
4	No Direct Line of Sight to System Required	4
5	Safety	4
6	Maneuverability	4
7	Range	3

8	Load Capacity Around 2lbs	3
9	Mechanism for Product Transport	3
10	Battery Life	3
11	Controller Portability	2
12	Maximum Flying Height	2
13	Flight Speed	2

Quality Function Deployment (QFD)

Table 2. Quality Function Deployment Chart for the proposed UAV system

Task Specifications	Microcontroller													Robotic Arm		Row Number	Row Weight	Importance
	Flying Height	Flying Speed	Payload Capacity	Flying Accuracy	Battery Life	Cost	Flying Range	Motors	Input/Output Ports	Program Language	Power Consumption	Wi-Fi Range	Diverse Gesture	Size of Payload	Power Consumption			
Customer Needs	Flying Height	Flying Speed	Payload Capacity	Flying Accuracy	Battery Life	Cost	Flying Range	Motors	Input/Output Ports	Program Language	Power Consumption	Wi-Fi Range	Diverse Gesture	Size of Payload	Power Consumption	Row Number	Row Weight	Importance
Obstacle Avoidance	x	x	x	x				x								1	11%	5
Manual Override									x				x			2	11%	5
Gesture Control	x	x	x	xx						x		x	xx			3	9%	4
Direct Line of Sight to UAV				xx								x				4	9%	4
Safety	x	xx	x	x									x			5	9%	4
Maneuverability		x		x			x	x	x					x		6	9%	4
Range	x	x					xx					xx				7	7%	3
Load Capacity Around 2 lbs	x	x	xx	x	x			x						x	x	8	7%	3
Mechanism for Product Transport					x	x								x	x	9	7%	3
Battery Life	x	x	xx		xx			xx			xx				xx	10	7%	3
Controller Portability						x				x		x				11	5%	2
Maximum Flying Height	xx		xx					xx								12	5%	2
Flight Speed		xx	xx					xx								13	5%	2
Units	m	m/s	kg	%	min	\$	m	Ct	Ct	Type	W	m	Ct	cm ³	W			
Column Number	1	2	3	4	5	6	7	8	9	10	11	12	13	14	15			
Marginal Value	1	1	1	50	10	1500	20	6	5	C++	5	20	1	1	5			
Ideal Value	3	3	2.5	100	20	1000	100	4	10	C	3.5	100	10	600	3.5			

Table 2 helps determine the importance of each of the parameters of the engineering design. It is a helpful tool to help with future decisions concerning product design. The cells contain x's which declare the importance of the connection between the column and row. A single x is of the

lowest importance escalating up to three x's which means the connection is of the highest importance.

There were many things learned from this table, but the one that affected the design the most was the motor column showing all of the different aspects of the design that the motors affected. This affected the choice of keeping the original motors or upgrading to more powerful motors. In the end it was chosen to upgrade the motors to increase payload. Another aspect that changed the decisions for the design was the Wi-Fi Range column. This column allowed for a reconsideration of the communication method used for controlling the quad-copter. It prompted thought of the controllable distance versus the distance for the video feedback. It was important to have a larger range for the controller than for the video to allow for a safe landing in the event of a failure.

Conceptual Development

The transportation system's major conceptual components were divided into six categories. Each category was researched according to each design above and evaluated based on the engineering specification. The process was completed to determine the best overall conceptual design from the initially developed concepts in order to fulfill the desired needs and applications.

Input sensor or camera is the first category. There are three different sensor or camera options for the different designs as presented in Table 3. The first option is the Xbox Kinect Sensor which would be easy to implement, but the range of the sensor is poor because it cannot detect at small distances. The second option is the Senz3D camera which is easy to implement because of the documentation on the sensor, and also has a workable range good for small distances. The last option is the PointGrab software with a 2D camera which has a low cost, but the ease of use and range are poor. The options were ranked out of 20 points and given a total score out of 5 points.

Table 3. Input Sensor or Camera Options

		Xbox Kinect Sensor ³	Senz3D Camera with Intel SDK ¹	PointGrab Software with 2D Camera ⁶
Evaluation Criteria	Weight (%)	Scale (1-5)	Scale (1-5)	Scale (1-5)
Close Range	20	1	3	2
Cost	20	2	3	5
Ease of Use	40	3	4	2
Implementation	20	4	4	3
	Total Score	2.6	3.6	2.8
	Rank	10	14	12

The weight of each criteria was determined by importance to the overall goal of the project. This gave Ease of Use double the weight of the other criteria, because it coincides with the choice of using gestures for the control media. It was important from the onset to make an easily controlled system for all users. The other criteria split the remaining percentage due to the relative importance of each being roughly equal.

Communication medium is the second category. There are three different communication medium options for the different designs as presented in Table 4. The first option is Radio

Frequency Transmission which is what a normal controller would use. The option performs well with distance, but performs low with throughput and transmitting multiple signals simultaneously. The second option is Xbee which also performs well with distance, and is fairly easy to send multiple signals. The last option is Wi-Fi transmission which has a lower distance but has a great deal of throughput and can easily send multiple signals. The options were ranked out of 25 points and given a total score out of 5 points. In this category Xbee had a higher total score and Wi-Fi had a higher rank, since the total score is based on the weight of the criteria it was held in a higher regard when the decision was made as to which component should be included in the system.

The weight percent of these criteria were based on Table 1 and the need for differentiation between components. The cost was given a low weight since each of the components were roughly equal in comparison and would not affect the outcome of the choice, but it was important to still include the cost since it is still a factor for any component. Distance was most important due to the range requirements compared to the other categories that weigh more heavily on how to achieve the design rather than the design itself. Ease of implementation and Ease of sending multiple signals were weighted more than throughput and cost due to the affect that each had on the time constraints of the project and the design work.

Table 4. Communication Medium Options

		Radio Frequency⁷	Xbee⁸	Wi-Fi⁹
Evaluation Criteria	Weight (%)	Scale (1-5)	Scale (1-5)	Scale (1-5)
Distance	30	5	5	2
Throughput	10	2	3	5
Ease of Implementation	25	5	3	4
Ease of sending multiple signals	25	3	4	5
Cost	10	3	3	3
Total Score		4	3.85	3.65
Rank		17	18	19

Microcontrollers is the third category. There are two different microcontroller options for the different designs as presented in Table 5. The first option for a controller is an Arduino. The Arduino does not consume a lot of power, and has a decent processing speed. The second option, the Raspberry Pi, has more power consumption, but a greater processing speed. The options were ranked out of 20 points and given a total score out of 5 points.

The processing speed was weighted the highest due to the need for video processing and how much that affects the functionality of the system. Power Consumption and Input/Output Ports were weighted the same due to the ability to differentiate the components and the importance to the design. As seen in Table 1 allowing the system to fly without direct line of sight was ranked higher than battery life as well as other attributes relating the requirement of the I/O ports. The cost was

weighted lower due to relative cost of these components to the rest of the system and the overall budget.

Table 5. Microcontroller Options

		Arduino Microcontroller¹⁰	Raspberry Pi Microcontroller¹¹
Evaluation Criteria	Weight (%)	Scale (1-5)	Scale (1-5)
Power Consumption	25	5	4
Input/Output Ports	25	3	4
Processing Speed	35	3	5
Cost	15	4	3
	Total Score	3.65	4.2
	Rank	15	16

Means of transportation is the fourth category. There are four different Transportation Means options for the different designs as presented in Table 6.. The ELEV-8 copters perform well with controllability and speed, but the Hex copter has a greater payload because of the addition of two extra motors at the cost of some battery life. The rover seems like a good option in terms of controllability, programming the different motors to work is a simple task. The product however will need to be good at obstacle avoidance and with one of the quad-copter options it would be easier because of the use of the Z axis (height) in terms of moving. Also the project will possibly need to navigate flights of stairs which would be difficult with a wheeled rover. The Aeroquad copter has a large battery life but the controllability is poor because of the lack of flight stability systems on the copter itself. The options were ranked out of 40 points and given a total score out of 5 points.

Table 6. Transportation Means Options

		Elev-8 Hex Copter¹²	Elev-8 Quad Copter¹³	Lynxmotion A4WD1 Rover¹⁴	Aeroquad copter¹⁵
Evaluation Criteria	Weight (%)	Scale (1-5)	Scale (1-5)	Scale (1-5)	Scale (1-5)
Battery Life	15	2	3	3	5
Payload	20	4	2	3	4
Speed	5	4	4	2	2
Controllability	20	4	4	5	2
Durability	5	3	3	4	4
Reparability	5	3	3	3	3
Safety	20	2	2	4	5
Cost	10	2	3	5	4
	Total Score	3.15	2.85	3.8	3.8
	Rank	25	23	29	29

The weights of the criterion are again related to the rankings as described in Table 1 with payload, controllability and safety holding similar weights. Battery life is the next highest weight due to the ranking being lower than the first three. Again, cost is important to any system, but due to all options being well within the acceptable range of the budget confinements the weight was low. As flight speed, durability, and repairability were not heavily weighted in Table 1 they are also not heavily weighted in Table 6.

Pickup mechanisms are the fifth category. There are four different pickup mechanism options for the different designs as presented in Table 7. The first option, the Makeblock Strong gripper, has the size to pick up large objects and good power consumption, but lacks in cost. The electromagnet for picking up objects would not be feasible when used with the quad-copter. The electromagnet would have an effect on the electric motors located on the quad-copter thus causing possible failure of the quad-copter which could affect safety as well as whether or not the object is successfully transferred from one location to the next. The Robotic arm has a small payload and has a small gripping size. The last option is the 2DOF Robot Claw which has good size, power consumption, and durability. The options were ranked out of 25 points and given a total score out of 5 points.

Power Consumption was the highest weighted in these criterion due to the rank in Table 1 as well as the affect it has on the overall system performance. Payload, size. amd durability were weigted the same due to each having the ability to equally affect the system performance.

Table 7. Pickup Mechanism Options

Evaluation Criteria	Weight (%)	Makeblock Strong Robot Gripper ¹⁶	Electromagnet ¹⁷	Rover Arm ¹⁸	2DOF Aluminum Robot Claw ¹⁹
		Scale (1-5)	Scale (1-5)	Scale (1-5)	Scale (1-5)
Payload	20	3	4	1	3
Size	20	4	1	2	5
Power Consumption	30	4	2	n/a	5
Durability	20	3	4	3	5
Cost	10	2	4	3	5
	Total Score	3.4	2.8	2.5	4.6
	Rank	16	15	9	23

Camera feedback module is the last category. There are four different camera feedback module options for the different designs as presented in Table 8. The option comprised of a GoPro camera has almost direct ability to livestream and good battery life, but is the most expensive of the four options. The CMOS camera module has good livestreaming capabilities and is the least expensive of the options. The Raspberry Pi camera has good power consumption and battery life. The IP camera also has ease of ability to livestream, but lacks in video quality. The options were ranked out of 25 points and given a total score out of 5 points.

The ability to livestream was weighted the highest, because it is important to have useful feedback from the quad-copter and it outranks the other criteria in this category. Power consumption was weighted the next highest due to the rank it has in Table 1 compared to the other criteria, with cost weighted the lowest with the components remaining within the overall budget.

Table 8. Camera Feedback Module Options

		GoPro Camera²⁰	CMOS Camera Module²¹	Raspberry Pi Camera²²	IP Camera²³
Evaluation Criteria	Weight (%)	Scale (1-5)	Scale (1-5)	Scale (1-5)	Scale (1-5)
Ability to livestream	30	5	4	2	5
Power Consumption	25	4	2	5	5
Battery life	20	5	4	5	3
Video Quality	15	5	3	3	2
Cost	10	2	5	4	3
	Total Score	4.45	3.45	3.7	3.95
	Rank	21	18	19	18

Conceptual Design

For the transportation system’s design the ranking system used above was considered in picking the various sub-systems for the design. Overall the design consists of the sub-system with the highest total score.

This conceptual design inputs the desired gestures from the human to the Senz3D perceptual camera which will feed to a Microsoft surface. A program running on the Surface will be coded to send different signals for each gesture to the Xbee hardware which can communicate long distances and has an upside in the fact that it is point-to-point transmission of information. The benefit of the point-to-point transmission is there is virtually no issue of interference from other devices. The Xbee signal transmission will be received by another Xbee on a Raspberry Pi. The Raspberry Pi camera was chosen for this design because of its capability to process a video stream with ease. The Raspberry Pi also has input and output ports which can be used for controlling parts of the quad-copter or controlling the pickup mechanism. The transportation means for this design will be provided by the Elev-8 quad-copter.

The Elev-8 would be used because of its 2lb payload, maneuverable 4 blade system, abundance of underbody space for adding components, as well as having an onboard processor for flight control. To pick up objects for transportation a simple claw would be used to clasp a small object near 2lbs. In order for the user to be able to view the flight path of the quad-copter, the video feedback will be provided with a 5 Megapixel Raspberry Pi camera. The camera was designed specifically for the Raspberry Pi for essentially plug and play usage. The stream would be one of

the outputs of the Raspberry Pi itself, being sent over a Wi-Fi dongle. Wi-Fi was chosen because of the abundance of bandwidth that was not available with other mediums. The Surface mentioned above will receive the Wi-Fi video feed and display it for the user. A rough assembly of this design can be seen below in Figure 2. In this design there is a small servo motor added to the elev-8 to rotate the camera from straight forward to 90 degrees downward to look below the elev-8. This was done using channel 6 in the radio frequency transceiver that was not being used prior. It will be controlled through gesture motions that will be discussed later.



Figure 1: Senz3D Camera¹



Figure 2: Conceptual Design

Economic, Environmental, and Ethical Concerns

The chosen system that has been outlined in this paper will contain materials that are hazardous to the environment. They are common materials that are typically used in today's manufacturing world, but to ensure full disclosure they are being acknowledged in this section. The delivery system is made of metal and plastic components and will emit electromagnetic signals, these signals can negatively affect various animals²⁴. The aluminum and plastic components of the ELEV-8 quad-copter can take decades to centuries to deteriorate²⁵. Plastics are known to never completely biodegrade and many common plastics partially degrade into Bisphenol A or BPA and PS oligomer. These byproducts are major health concerns to humans and other organisms²⁶. The batteries used in this design contain corrosive materials which pose a known danger to the environment. Any batteries that are no longer usable are to be recycled by consumers, as well as all other components of the system that would otherwise be sent to a landfill.

Animals that are found to react negatively to electromagnetic wave pollution are cows, mice, and bees²⁴. This system uses local wireless communication, and as long as it is not used around these specified animals the contribution of this design to EM wave pollution will be minimal. This system is not to be used to negatively impact society in any way, shape, or form. It is not intended to be used to harm people or animals, but instead is designed to positively impact the world. This product was designed with the consumer's safety in mind, as it is realized the system will be ensured to be safe and robust.

Engineering Standards

When creating a product it is known that certain standards must be met. These standards are set by different institutions that specialize in a respective field. For example, when using radio frequency in products IEEE has set standards that companies must follow. This product design is required to follow many IEEE standards such as radio frequency transmission, Xbee transmission, and Wi-Fi transmission.

The standard IEEE 802.11 b/g/n will pertain to the project by the Wi-Fi communication that will be used. The reason for using b/g/n is because of the frequencies and bandwidths used by the modules in this project. The video streaming and communication will be performed at the frequencies discussed in those sections. The classifications are based on not only frequencies but also the type of modulation. The three different sub standards (b/g/n) can use Direct-Sequence Spread Spectrum and Orthogonal Frequency Division Multiplexing. There are multiple data stream rates that can be applied to these sub standards. Because of the devices being used such as Wi-Fi adapters and camera that stream using Wi-Fi; these standards must be fit because the products will be off the shelf.

The FAA Advisory Circular 91-57 standard will apply to the transportation means from the project which has been chosen to be an automatic copter. The copter being used is considered a model of a larger scale copter. This standard specifies that the operating site is sufficient distance away from highly populated areas. The aircraft should not be flown in the presence of spectators until it is tested and proven airworthy. The aircraft should not be flown higher than 400 feet above the surface and if flown within three miles of an airport, the air traffic facility must be notified. Also the operator should give right of way to full scale aircraft. The operator should feel free to ask for assistance from airport traffic control station for compliance with these standards. The copter being used in the project must fall under these qualifications in order to be used for this project.

ISO 14539:2000 safety standard from International Safety Organization is about object handling with grippers. This safety standard will apply to the types of grippers mentioned in the standard definition. The two pronged claw chosen for the pickup mechanism for the project will fit into the types of grippers mentioned in the definition. The safety standard defines the types of grippers that can be used. The standard also defines which types of control can be used with the gripper's servos. For the gripper used in the project with a servo, a force command will be used because there will be no position signal sent; only a signal sent to force the gripper open or closed. The standard provides definitions for the acceptable types of gripping styles for loss of power to

the servo. The gripping style used will be self-holding because the servo will not open on its own because of the passive internal components, thus holding the objet steady in loss of power²⁷.

System Operation

This system has many parts and the operation is quite complex, but it is described for simplicity in Figure 3 below. The system will initially start as soon as the Senz3D camera picks up a gesture. This gesture will then be processed through Microsoft Visual Studios and be stored as a value. Each gesture will have a value associated with it. This will then be sent to the microcontroller via a serial port. The control signal will then be sent to the Elev-8 from a transceiver connected to a pulse-width-modulated port located on the controller. The Elev-8 will receive the commands from the transcierver. Then the transceiver will split the original signal into six individual pulses. These pulses are then processed by the onboard hoverfly processor to become different directions and actions. The sixth channel was used to add a servo motor that will change the direction of the camera which will allow the user to view the pickup mechanism while trying to obtain the payload.

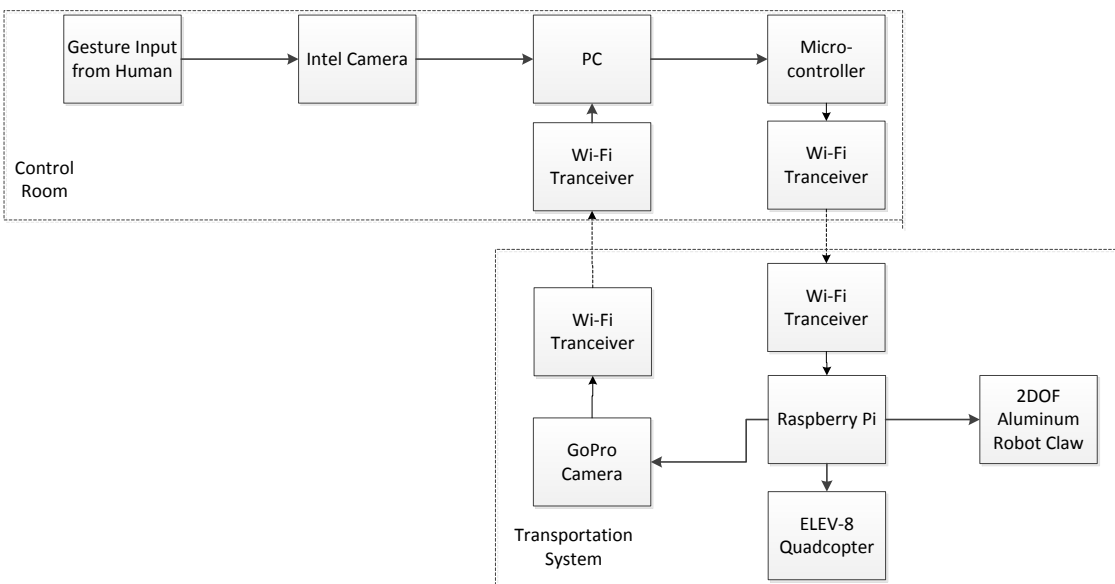

Figure 3: Architecture of proposed System

The gestures will be one of the most important features with this program. When gesture input is first recognized it is then determined to be one of ten gestures: Thumbs Up, Thumbs Down, Peace Sign, Big 5, Wave, Circle, Swipe Left, Swipe Right, Swipe Up, or Swipe down. Each of the gestures controls a different part of a PPM signal pulse. For example a Thumbs Up gesture would change the second pulse which is the pulse that determines if the copter moves forward. There are six different pulses that can be controlled by the gestures. Once the change to the pulse has been made, the system will return to recognize the next input gesture. If no input gesture is recognized, the system will also return to the beginning to check for another gesture¹.

Table 9. Gesture Control Tasks

Gesture	Task
Peace	Turn On/Turn Off System
Swipe up	Gain altitude

Swipe down	Decrease altitude
Swipe left	Rotate left
Swipe right	Rotate right
Thumbs up	Move forward
Thumbs down	Move backward
Big 5	Stop
Wave	Camera rotates to forward view
Circle	Camera rotates down to pickup view

Preliminary Testing

During the construction and integration of the system tests have been run to assess some of the necessary functions as completion has progressed. An initial test that was able to be run was the communication between the microcontroller and the quad-copter. In order to use the transceiver from the radio controller a program was written that initialized the quad-copter and then effectively disabled it. This verified the ability to send commands to the quad-copter using the microcontroller as a simple controller. To further verify that gestures could control the quad-copter a test was designed to get an output on the microcontroller by displaying a gesture to the senz3D camera. If a thumbs up was given an LED would light up. After getting the output a section of code was developed to communicate to the quad-copter through the microcontroller and transceiver system. The peace sign was displayed to the senz3D camera and the quad-copter was initialized.

It was important to test the delay time of the system so the servo motor for the on-board camera module was attached to the sixth channel of the quad-copter's transceiver. When a thumbs up was given the servo rotated 90 degrees clockwise, and with a thumbs down the servo rotated 90 degrees counter-clockwise. The delay was tested by giving the command gesture and trying to clock the delay from the time the gesture was given to the time that the servo reacted. The time was not able to be measured due to the lack of a noticeable delay. In the near future there are plans to run further tests of the delay to quantify it. A timer is currently being added to the program to measure the time that it takes the to recognize the gesture.

The preliminary testing for the quad-copter payload and flight duration are currently on hold as one of the motors needs to be replaced before testing is possible. Once the new motor arrives it will be quickly changed and the stated payload of 2 lbs. will be verified. The estimated flight duration is fifteen minutes and this will be able to be confirmed once the quad-copter is again operational.

Conclusion

The promise of perceptual computing can be seen in the progress of this system. Taking user gestures and transforming them to actual movement of an object is an exciting new capability. The transportation system is nearing completion and preliminary testing has given hope that the system will operate in the desired project parameters. This project is a stepping stone to future advancements in hands-free computing. Once the limitations and the capabilities of the technology are known improvements can be made and expanded upon. The quad-copter itself is a new

technology and as greater advancements in battery technology are made and micro-controller size is reduced, there will be improved payload capacity and more maneuverable systems.

References

- [1]. Intel® Perceptual Computing SDK 201, [Online], Available: <https://software.intel.com/en-us/perceptual-computing-sdk>
- [2]. Pei Jia, Huosheng H. Hu, Tao Lu, Kui Yuan, (2007) "Head gesture recognition for hands-free control of an intelligent wheelchair", Industrial Robot: An International Journal, Vol. 34 Iss: 1, pp.60 – 68
- [3]. "Kinect Sensor". Retrieved November, 2014 Available: <http://www.xbox.com/en-US/xbox-one/accessories/kinect-for-xbox-one>
- [4]. Mullins, T , "The Matternet Vision and Design". Retrieved November, 2014 Available: <http://tracymullins.wordpress.com/cultural-research/4-the-matternet-vision-and-design/>
- [5]. AR.Drone 2.0. Parrot New Wi-fi Quadricopter - AR.Drone.com - HD Camera - Civil Drone – Parrot, [Online]. Available: <http://ardrone2.parrot.com/>.
- [6]. "Pointgrab". Retrieved November, 2014 Available: <http://www.pointgrab.com/>
- [7]. "RF Module (Transmitter & Receiver)". Available: <http://www.engineersgarage.com/electronic-components/rf-module-transmitter-receiver>
- [8]. "Linksys Wi-Fi USB Adapter ". Available: http://store.linksys.com/products/linksys-other-adapters_stcVVcatId552067VVviewcat.htm
- [9]. "XBee Module". Retrieved November, 2014 Available: <http://www.adafruit.com/blog/category/xbee/>
- [10]. "Arduino". Retrieved November, 2014 Available: <http://www.arduino.cc/>
- [11]. "Raspberry Pi". Retrieved November, 2014 Available: <http://www.raspberrypi.org/>
- [12]. "ELEV-8 Hex Upgrade Kit". Retrieved November, 2014 Available: <http://www.makershed.com/products/elev-8-hex-upgrade-kit>
- [13]. "ELEV-8 Quadcopter Kit ". Available: <http://www.parallax.com/product/80000>
- [14]. "Lynxmotion Aluminum A4WD1 Rover Kit". Retrieved November, 2014 Available: <http://www.robotshop.com/en/4wd1-robot-aluminum-kit.html>
- [15]. "AeroQuad Cyclone ARF Kit". Retrieved November, 2014 Available: http://www.aeroquadstore.com/AeroQuad_Kits_s/40.htm
- [16]. "Makeblock Strong Robot Gripper Robotic Mechanical Claw Arm". Retrieved November, 2014 Available: <http://www.amazon.com/Makeblock-Strong-Gripper-RoboticMechanical/dp/B00GSKI57Q>
- [17]. "Magnets from Mini to Mighty". Retrieved November, 2014 Available: <http://www.magnet.fsu.edu/education/tutorials/magnetacademy/magnets/page4.html>
- [18]. "OWI Robotic Arm Edge". Retrieved November, 2014 Available: <http://www.amazon.com/OWI-OWI-535-Robotic-Arm-Edge/dp/B0017OFRCY>
- [19]. "Aluminum Robot Arm Clamp Claw Mount Kit". Retrieved November, 2014 Available: http://www.aliexpress.com/item/1-Set-2-DOF-Aluminum-Robot-Arm-Clamp-Claw-Mount-Kit-No-servo-Un-assembly-Fit/1315775857.html?af=ppc&isdl=y&src=Google&albch=Google&aff_short_key=UneMJZVf&cv=102080000009001&ptsid=102000000013003&crea=51413220145&plac=&netw=g&device=c&aff_short_key=UneMJZVf&cv=102000000013003&gclid=Cj0KEQIA9eamBRDqvIz_qPbVteABEiQAnIBTEJG81qdIOXKxMwBC4gZC3L-p3cnNgIulvX1fedyrjsaAmwy8P8HAQ
- [20]. "GoPro HERO4". Retrieved November, 2014 Available: <http://shop.gopro.com/cameras>
- [21]. "Camera Module Lens CMOS". Retrieved November, 2014 Available: <http://www.e-consystems.com/IMP-Customlens-NIR-Camera-module.asp>
- [22]. "CAMERA MODULE". Retrieved November, 2014 Available: <http://www.raspberrypi.org/products/camera-module/>
- [23]. "Wireless Ip Camera". Retrieved November, 2014 Available: <http://www.swann.com/us/index.php/swnvk-460kh2>
- [24]. "EM Pollution affects Animals". Retrieved November, 2014 Available: http://www.electromagnetic-pollution.com/main/page_biological_effects_animal_effects.html

- [25]. T. W. t. Go, "Polystyrene Factsheet," 2008. [Online]. Available: <http://isites.harvard.edu/fs/docs/icb.topic967858.files/PolystyreneFactSheets.pdf>.
- [26]. "How long does it take for plastics to biodegrade?" Retrieved November, 2014 Available: <http://science.howstuffworks.com/science-vs-myth/everyday-myths/how-long-does-it-take-forplastics-to-biodegrade.htm>
- [27]. "IEEE Get Program". Retrieved November, 2014 Available: <http://standards.ieee.org/getieee802/download/802.11-2012.pdf>