

SAE Baja Multi-Speed Transmission/Transaxle

Kaylah Bovard, Wyatt McClead

Undergraduate Students

Farshid Zabihian

Winnie Fu

Bernhard Bettig

Assistant Professor

Department of Mechanical Engineering

West Virginia University Institute of Technology

Montgomery, West Virginia-25136, US

Email: kaylah.bovard@gmail.com, wmclead@mix.wvu.edu, farshid.zabihian@mail.wvu.edu

ABSTRACT

The SAE Mini Baja team requires a custom, multispeed transmission for their vehicle. The team utilized concurrent engineering with the Baja design team to ensure a design for a transmission that will best suit the vehicle. This manuscript details the engineering and design of a two speed (10:1 and 7:1) custom transmission. SolidWorks drawings and design matrices were used to come to the best conclusions. The overall purpose of the project is to design a transaxle that will make the vehicle successful. This paper will outline the steps taken to design a transaxle that will be manufactured later.

INTRODUCTION

The Society of Automotive Engineers sponsors an engineering design competition every year called the Mini Baja competition. Teams design, fabricate, and race a single seat vehicle completely from scratch except for the 10 horsepower engine that is provided. The vehicle must perform five dynamic events as well as a four hour endurance race. The events range from a sled pull to maneuverability, and the track is typically one of rough terrain and multiple obstacles. In order to be competitive in every event, a multispeed transmission is a necessity. The past two competitions were opportunities to realize the most beneficial designs.

Two years ago, the competition in Rochester NY provided a track that was swamped and hilly. That vehicle utilized a gear ratio of 5.4. The low power was not advantageous to the competitiveness in the endurance race as well as the hill climb. The next year's team tried to compensate by purchasing a transmission with a gear ratio of 13.25 and reverse capabilities. While both proved to be more valuable (especially in the sled pull), the high gearing slowed down the maximum speed. It allowed no room for variability and prohibited the vehicle from maintaining any speed above thirteen miles per hour. The opportunity of having gearing options would enable the Baja Buggy to be more versatile when needed to provide strictly speed in one event and still produce a lot of power in another.

A transmission serves to increase the flexibility of the power of a vehicle that uses a reasonably sized engine. Even though the need for modifications of engines to increase the engine's speed and torque, the transmissions role is used to deliver the demanded performance. The modern transmission is used for the engine's control strategy [1]. When choosing a design

for a transmission, there are many things to consider. Some of them include, but are not limited to: gear ratios, number of speeds made available (two, three, four, and five), reverse capability, time it takes to manufacture, difficulty level of execution, and the overall size/weight of the design. Each of these parameters has influence on the others. For example, a five speed would provide the most variability, but would require more gears, more space, and more time in manufacturing. Choosing a final design will come down to choosing the best features for the overall best product.

DESIGN

The first step in designing a transmission was to analyze each parameter, control variable, and constraint the final product would require. A design parameter is a property “whose values determine the form and behavior of a design” [2]. The parameters included: overall weight, size (dimensions), and build time. Constraints are fixed parameters that limit design freedom, and for this project included: the size of the differential and the revolutions per minute of the engine, as that is not allowed to be touched in order to compete. The variable aspects of this design are parameters with which the engineer has design freedom [2]. The variables in this process were the number of speeds, gear ratios of each, materials used, cost of each material or part, and the toughness of each part as well as the overall design.

The first aspect in design was to incorporate the constraints. Differentials in a vehicle are not needed unless it has to turn. They allow each wheel to turn independently and at their own speed. There are several different locking capabilities available, including limited slip, completely locked, and completely open. When one wheel spins, a limited slip differential will make the clutch engage, providing resistance to rotation [3]. For an off-road application like this SAE competition, a limited slip needs to be used because of the prevalence of turns where one wheel will be off the ground. In order to choose a differential, the team collaborated with the Baja SAE team to determine which qualities the piece was to possess. The three total options for a differential of this size were: Yamaha Viking Limited Slip, Honda Cam N Paw Open Differential, and a locked rear end. A locked rear end would not require an extra piece, but it would also be disadvantageous in the maneuverability competition. Table 1 shows the house of quality used to determine which of the two differentials would be best in this design. Because the differential determines the design of the whole transmission, the purpose of this house of quality was to weigh which differences in the differentials were most important.

TABLE 1. House of Quality in Choosing a Differential

Direction of Improvement							
		+	-	+	+	-	
Customer Requirements (What)	Design Requirements (How)	Importance (1-6)	Durability	Weight	Type	Integration	Complexity
	Improve	Speed	5	3	5		
Quality		3	5		4	3	
Diversity		1		4		2	4
Reduce	Gear Ratio	6		4		3	
	Weight	2	5	5	3		
	Cost	4	5	3	3		4
Total			18	21	10	8	15

The vehicle needs to reduce weight, gear ratio and cost, while improving the speed, quality, and diversity of the vehicle. The requirements are directly affected by the durability, weight, type, integration, and complexity of the differential. The durability was found to be most important in designing, which is why the part chosen was the Viking. It is a piece from the Viking 700-YXM700DEG-2014. The total price was \$564.99 and is a limited slip electronic locking device [4]. Its effect on the durability of the vehicle was greater than the other because of its ability to engage the clutch. Figure 1 shows the differential that was chosen and bought with the SAE funds.



FIGURE 1. Viking 700-YXM700DEG-2014 Differential [1]

The next part of design work was in determining the amount of speed variations were going to provide the Baja team with the best power options. Transmissions can be made up to have one,

two, three, four, and five speeds with or without reverse capabilities. A decision matrix (Table 2) was made to compare new design concepts to the transmission used in last year's vehicle (Dana FNR12). The areas to consider were the weight, cost, and manufacturability without compromising variability. Each step up in number of ratios means a step up in weight. Manufacturability is the extent to which a good can be manufactured with relative ease at minimum cost and maximum reliability [5]. We want to provide the vehicle with a transmission that is cost effective that also allows a high gear for power and a low gear for speed. The DANA FNR12 was the transmission used last year that utilized a 13.25 reduction with reverse. It weighed 35 pounds, cost \$900, and had one shifter. Any design with more than two speeds would be more difficult to manufacture ourselves. The Pugh Analysis utilized a "greater than," "equal to," and "less than" grading system. All of the options for the timing criteria were "less than" because it takes a significant amount of time more to manufacture than to order a premade one. Any more than one forward speed was better and the weight of anything more than two options were more costly and heavy. Therefore, we chose to go with a two speed; a high gear ratio and a medium ratio that provides enough speed.

TABLE 2. Number of Speed Decision Matrix

Pugh Analysis

Alternatives	Baseline	1	2	3	4	5
Criteria (mark a '+' or '-')	DANA FNR12	1 Speed	2 Speed	3 Speed	4 Speed	5 Speed
Weight	Datum	+	S	-	-	-
Cost		+	S	-	-	-
Timing		-	-	-	-	-
Manufacturability		S	S	-	-	-
Ease of Assembly		-	-	-	-	-
Variability		-	+	+	+	+
Shifting Complexity		-	-	-	-	-
# of Pluses			2	1	1	1
# of Minuses		4	3	6	6	6

The next step of the design process involved choosing the gear ratios of each speed. The theoretical speed of the final design can be calculated using the tire size, possible gear reduction ratio, and the revolutions per minute of the engine. Table 4 shows the given values of RPMs, tire size, and distance per rotation of each tire size. The purpose of having two different tire sizes is that tire size can be changed to acquire the ground clearance and speed desired. The Baja team has predetermined the tire sizes that were going to be used. This is a set parameter but has a

slight variability that can be used to our advantage to acquire the wanted gear ratios. The results are shown in Table 4 [6].

TABLE 3. Given Values for Speed Calculations

Engine (rpm):	3800
Engine (rph):	228000
Tire Size (in):	20
Distance per rotation (in):	62.83185
Distance per rotation (mi):	0.000992
Tire Size (in):	21
Distance per rotation (in):	65.97345
Distance per rotation (mi):	0.001041

TABLE 4. Speed Calculations

Gear Ratio	Max Speed 20" Tire (mph)	Max Speed 21" Tire (mph)
3:1	75.37	79.13
4:1	56.52	59.35
5:1	45.22	47.48
6:1	37.68	39.57
7:1	32.30	33.91
8:1	28.26	29.68
9:1	25.12	26.38
10:1	22.61	23.74
11:1	20.55	21.58
12:1	18.84	19.78
13:1	17.39	18.26

Table 4 shows the max speeds the vehicle could theoretically go based on the parameters mentioned previously. The decision matrix where each Baja event was evaluated in comparison with the transmission used on last year's design, which used a gear ratio of 13.25:1. The events were analyzed in terms of competitiveness. The "less than," "equal to," and "greater than" scale was used again and each ratio was compared to the same DANA FNR12 transmission used last year. If the power provided by the gear ratio would perform better in the hill climb, it got a "+." The final low gear chosen was a 7:1 ratio because of its speed of 32.3-33.91mph paired with the positive outcomes from the decision matrix shown in Table 5 (+ better, - worse, and s same).

TABLE 5. Gear Ratio Decision Matrix

Events	6:1	7:1	8:1	9:1	13.25:1
Endurance	+	+	+	-	Base
Acceleration	+	+	+	s	
Hill Climb	-	-	-	s	
Suspension and Traction	-	-	+	+	
Maneuverability	s	+	+	s	
+	2	3	4	1	
-	2	2	1	2	
s	1	0	0	3	

In order to choose the high gear, calculations were solely focused on the event that required the most amount of power: the hill climb. The total torque needed to carry a 500 pound vehicle (rough estimate given by the Baja team) can be determined using the following equations:

$$G_1 = G * \sin\theta = 500lb * \sin(40) = 321.4lb$$

$$Force\ per\ wheel = \frac{G_1}{2} = 160.7lb$$

$$Torque\ per\ Wheel = 160.7 * \frac{D}{2} = 160.7 * \frac{20}{2} * \frac{1}{12} = 133.9lbft$$

$$Total\ torque = Torque\ per\ wheel * 2 = 133.9 * 2 = 267.8lbft$$

$$Gear\ ratio = \frac{Total\ torque}{Torque\ of\ Motor} = \frac{267.8}{14.25} = 18.79$$

Where: G_1 = Weight of gravity tangent to the hill

θ = angle of the hill

D = diameter of the tire

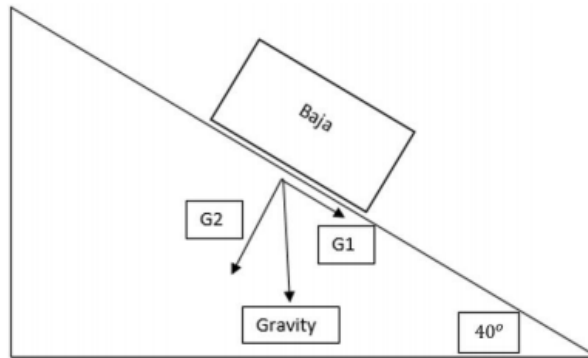

FIGURE 2. Hill Climb Gear Calculations [7]

The gear ratio needed is approximately a 19:1. However, these results don't account for the implementation of a continuously variable transmission (CVT). The CVT that attaches to the transmission that we are designing uses a set of masses that spin with the drive pulley creating centrifugal forces that are applied to the surface normal to the belt. This CVT adjusts the ratio depending on three main factors : "1) the centrifugal force generated which depends of the angular speed, weight of the masses, and radius, 2) the drive pulley spring stiffness, actuating against the centrifugal force, 3) the brake torque on the driven pulley and the stiffness of the torsional spring inside this" [8] The most important aspect of the CVT is its added gear reduction provided. The calculations proved that a gear reduction of 19:1 was needed, and the CVT will provide a 2:1 reduction, doubling the transmission's reduction. Therefore, if a 20:1 is needed, a 10:1 reduction in the gear box will be doubled with the CVT. The final decision for the two reductions is using a 10:1 and a 7:1.

The next step in the design process includes choosing the configuration of gears on their shafts as well as the type of gear (helical, bevel, or spur). In order to design a configuration, the type of gear was chosen based on weighted qualities. In order from most important to least important, the qualifiers were: availability of the gears when looking to order them, cost, efficiency, complexity in their alignment, and practicality of being able to get them configured in the right way.



FIGURE 3. Possible Types of Gears [9]

The types that can possibly be used in a transmission are spur, helical, and bevel. Table 6 shows the decision matrix where each type was rated compared to one another and then multiplied by the qualifier weight. Based on this analysis, spur gears were chosen to use in this design.

TABLE 6. Gear Type Decision Matrix

Weighted Multiplier	Quality	Spur	Helical	Bevel
4	Cost	3	2	1
5	Availability	3	2	1
1	Practicality	3	2	1
2	Complexity	3	2	1
3	Efficiency	1	3	2
		39	33	18

Gear ratios in a transmission can be obtained in a limited number of ways. However, gear sizes allow a multitude of possibilities for configuration. The center distance of each gear was decided upon based on the size constraints in the drive train as well as the diametral pitch of each gear. The following equations were used to determine the center distances between shafts [10].

$$P = \frac{N}{d} \quad d_1 = \frac{N_1}{P} \quad d_2 = \frac{N_2}{P} \quad c = \frac{d_1 + d_2}{2}$$

Where

P = diametral pitch

N = Number of teeth

d = base diameter

c = center distance

$$d_1 = \frac{N_1}{P} = \frac{60}{8} = 7.5 \text{ in}$$

$$d_2 = \frac{N_2}{P} = \frac{15}{8} = 1.875 \text{ in}$$

$$c_1 = \frac{d_1 + d_2}{2} = \frac{7.5 + 1.875}{2} = 4.6875 \text{ in}$$

$$d_3 = \frac{N_3}{P} = \frac{45}{8} = 5.625 \text{ in}$$

$$d_4 = \frac{N_4}{P} = \frac{20}{8} = 2.5 \text{ in}$$

$$c_2 = \frac{d_3 + d_4}{2} = \frac{5.625 + 2.5}{2} = 4.0625 \text{ in}$$

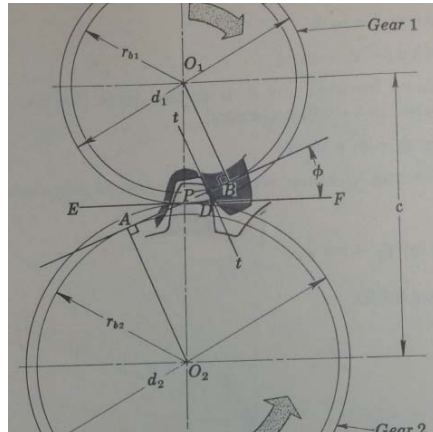

FIGURE 4. Center Distance Calculations [10]

Given the type of gear, diametral pitch of each, and the center distances, the next step is to design a configuration where the 7:1 and 10:1 reductions can be utilized. The shafts, gears, and differential were designed in SolidWorks. Figure 5 shows the initial configuration based on calculations and previous understanding of how gear ratios are reached.

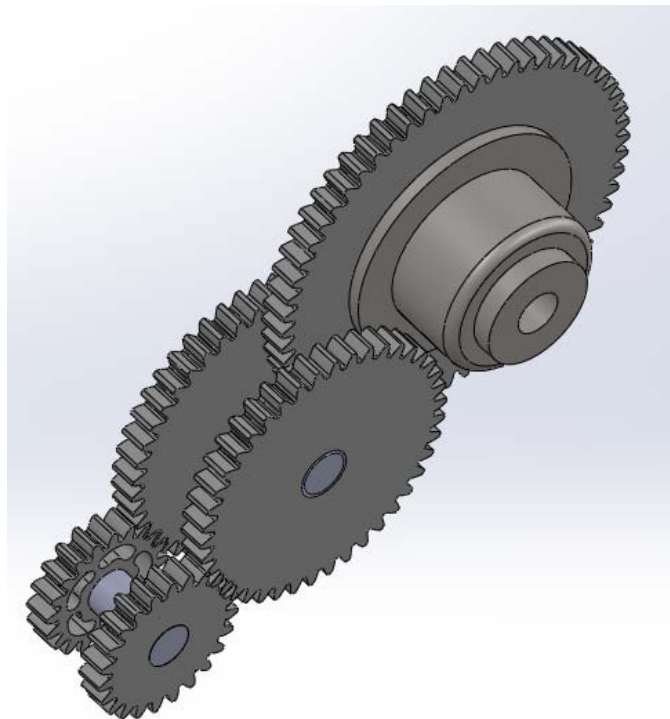

FIGURE 5. SolidWorks Gear Box Configuration

The last aspect to be designed was the case. Most transmission cases are manufactured out of a block of aluminum. However, other composite materials have been integrated before. The Materials Science and Engineering textbook provided information on three different types of composites that are used most often. These include: Carbon, Kevlar, and Glass fibers. From the reading, the lightest and strongest tensile strength material is the carbon weave, and the most impact resistant is the Kevlar [11]. This information was used to create a thorough decision matrix in order to determine which material to use in our final design. A carbon fiber case would be simple to manufacture by creating foam molds that would be one time use molds. These could be shaped and formed to meet our design. The fibers would then be laid out over the molds and a resin would be used to cover the fibers and create a structural surface. Once the resin is set, the mold could be dissolved and what would be left would be the case. This is a relatively simple process to be able to create a much lighter case design.

Lastly, the shifting mechanism must be designed in order for the driver to utilize each of the gear reductions. A typical configuration operates with shifting forks that require room on a shaft to lock the needed gears into place. However, this is not the only available option. The team looked into possible mechanisms that would allow smoother transition while maintaining a lightweight and compact design. A ball lock shifting mechanism is just that: a shifter that reduces the size by 50%, the weight by about 5 pounds, and the overall cost of parts needed. Figure 6 shows how a typical 4 speed transmission would work with a ball lock. This device has been used in racing motorcycles, but has not been very popular among larger vehicles because of the limited torque the ball bearings can withstand [12]. However, this type of shifter is ideal for a 10 horsepower engine and would greatly benefit the overall performance of the mini Baja vehicle.

BALL LOCK SHIFTER MECHANISM

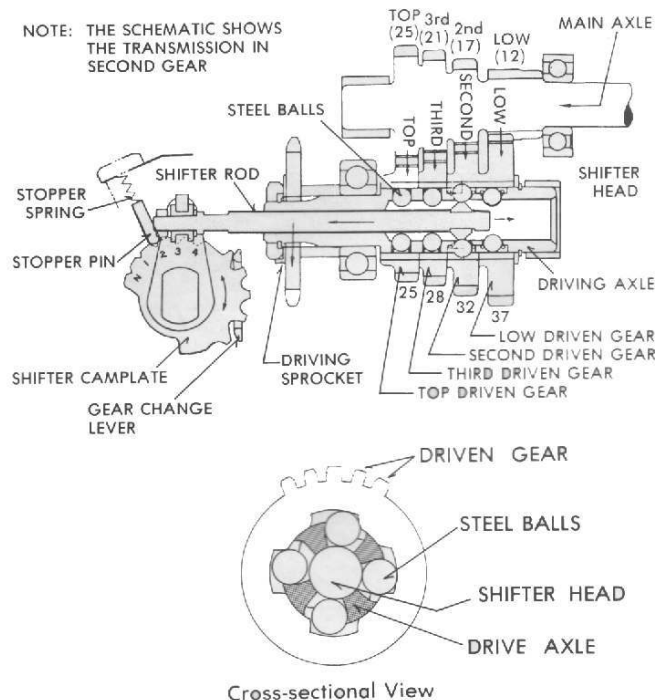

FIGURE 6. Ball Lock Shifter Mechanism [13]

CONCLUSION

This project of designing a transmission for the Baja SAE vehicle has been very successful. The main decisions have been made: two speeds, 10:1 and 7:1 gear ratios, ball lock shifting mechanism, and a Yamaha Viking Limited Slip differential. The team learned a lot about the steps it takes to make design decisions as well as manage time in a project of this caliber. The next steps are going to be to order parts, fabricate the design, and test the final product at competition. This manuscript was dedicated to perfecting the design and the next shall be ensuring a working product.

ACKNOWLEDGMENT

The contribution by Dr. Bernhard Bettig and Dr. Winnie Fu is greatly appreciated.

REFERENCES

- [1] Gott, Philip G. "Why Is a Transmission Needed?" Introduction. *Changing Gears: The Development of the Automotive Transmission*. Warrendale, PA: Society of Automotive Engineers, 1991. N. pag. Print.
- [2] Dieter, George Ellwood., and Linda C. Schmidt. "Problem Definition and Need Identification." *Engineering Design*. New York: McGraw-Hill, 2013. 95. Print.
- [3] Stone, Richard, and Jeffrey K. Ball. *Automotive Engineering Fundamentals*. Warrendale, PA: SAE International, 2004. Print.
- [4] "VIKING 700 - YXM700DEG - 2014." *Parts Finder*. Lemon and Barrett's, n.d. Web. 08 Oct. 2014.
- [5] "What Is Manufacturability? Definition and Meaning." *BusinessDictionary.com*. N.p., n.d. Web. 11 Nov. 2014.
- [6] "DuPont Engineering Guidelines." *DuPont Engineering Guidelines*. N.p., n.d. Web. 11 Nov. 2014.
- [7] Richard Budynas, and J Keith Nisbett. *Mechanical Engineering Design*. 9th. 1021. New York: McGraw-Hill, 2011. Print.
- [8] Martinez, J., Corona, D., Diaz, S., and Boccardo, R., "Characterization of an Adjustable Centrifugal Continuously Variable Transmission for a Baja SAE Prototype.," SAE Technical Paper 2010-01-0861, 2010, doi:10.4271/2010-01-0861.
- [9] "Alibaba.com." Bevel Gears/spur Gears/gear Sets/spiral Bevel Gear, View Bevel Gear, RTR Product Details from Dalian Running Engineering Company Limited on. N.p., n.d. Web. 11 Nov. 2014.
- [10] Wilson, Charles E., J. Peter. Sadler, and Walter J. Michels. *Kinematics and Dynamics of Machinery*. New York: Harper & Row, 1983. Print.
- [11] Callister, William D. *Materials Science and Engineering: An Introduction* 8e. N.p.: n.p., n.d. Print.
- [12] Cameron, Kevin. "Honda's Secret MotoGP Transmission – Racing Honda Has Come into the 2011 MotoGP Season Strong, This New Transmission Is Part of the Reason." *Cycle World*. N.p., 06 Apr. 2011. Web. 18 Nov. 2014.
- [13] "GEAR SHIFTERS." *Dan's Motorcycle*. N.p., n.d. Web. 18 Nov. 2014.