

# Bridging Communication Systems and Circuits with PSPICE

Andrew Rusek and Subramaniam Ganesan,  
Oakland University, [rusek@oakland.edu](mailto:rusek@oakland.edu), [Ganesan@oakland.edu](mailto:Ganesan@oakland.edu)

**Abstract--** PSPICE has many interesting system blocks and circuit components which can be connected together or used separately. We have developed a broad variety of student edition PSPICE macromodules for use in class room and laboratory teaching, including units that simulate pulse width modulators and demodulators, delta encoders and decoders, generic class C amplifiers, frequency synthesizers, noise generators, band pass filters, AM modulator/ demodulators with noise and interference, analog correlators, oscillators, and phase lock loops. This paper presents details of the above modules, and also describes the use of the PSPICE modules in the communication courses and circuit courses.

## Introduction

PSPICE has many interesting system blocks and circuit components which can be connected together or used separately. Blocks such as Analog Multipliers, Amplitude Limiters, Generic Amplifiers, Laplace Blocks, Ideal Transmission Lines, Coupled Transmission Lines, Arbitrary Function Blocks with Two or Three Inputs, Summing and Difference Nodes, Generic Filters, Trigonometric and Log Function Blocks, etc. are available in addition to many passive and active circuit components create an excellent base for system/circuit preparation. This could be controlled by built-in FFT analysis, parametric sweep of component/system parameter values, time-domain, frequency-domain analyses, possibility of reading external tables (eg. pseudo-random numbers for noise signal generation), optimization procedures could show max or min values while sweeping, etc.

Obviously, direct circuit implementations are very natural, since even active circuit components can be modified to create new microwave circuits from LF basic diodes and/or transistors. Typical example: old 2N2222 transistor operating within MHz frequency ranges can be "reshaped" by changing its parameters to operate within GHz ranges. Some instruments e.g. Network Analyzers can be simulated to extract S-parameters for further analysis or design of microwave amplifiers using other special software that is based on S-parameters. The S parameters extracted by PSPICE Network Analyzer can be also used in many available MATLAB programs to continue design processes.

We have developed a broad variety of PSPICE macromodules for use in class room and laboratory teaching, including units that simulate pulse width modulators and demodulators, delta encoders and decoders, generic class C amplifiers, frequency synthesizers, noise generators, band pass filters, AM modulator/ demodulators with noise and interference, analog correlators, oscillators, and phase lock loops. Some selected circuits and the use of the PSPICE modules in the communication courses and circuit courses are given in the following section.

The PSPICE circuit and simulation discussed in the paper would make excellent additions to the class room or laboratory of any undergraduate communications systems course. Frequency hopping CDMA and other wireless techniques are difficult concepts to grasp and difficult to obtain practical experimental experience. Demonstrating many of the communication techniques through PSPICE simulations provides invaluable educational opportunity.

**Why PSPICE was applied**

The PSPICE educational version is free and pretty effective; number of components is limited, but sufficient in all presented cases. Each student can use PSPICE anywhere, as long as he or she has a computer, laptop, desktop, or net-book. Some of the features of PSPICE are:

1. Basic blocks are available, such as analog multipliers, summing blocks, difference blocks, integrators, differentiators, Laplace blocks, arbitrary function blocks; circuits, both analog and digital. Easy parameter changes, value sweeps, etc. Larger circuits can be integrated into blocks – book like units.
2. Time-domain, frequency-domain, Fourier analysis, Math operations on signals are possible
3. Post-processing is available.
4. Probe multichannel displays, like multichannel scopes, multichannel spectrum analyzers, y-x displays with easy scale changes.
5. Easy documentation collection

Other options: System View of Elanix, and VisSim/Comm of Visual Solutions, Inc. are not free and they do not include circuit components that could show possibility of laboratory implementation.

**Selected Circuit Examples**

In this section we illustrate a few basic functions. The circuit potential and noise level can be easily modified, interference added, more filtering effects are easy to modify to observe possible signal distortions. More noise effects could be also demonstrated. The material supports our Digital Communication Systems course, ECE 534 (graduate course). Initial part reviews classical material from ECE 437, Communication Systems (undergraduate course).

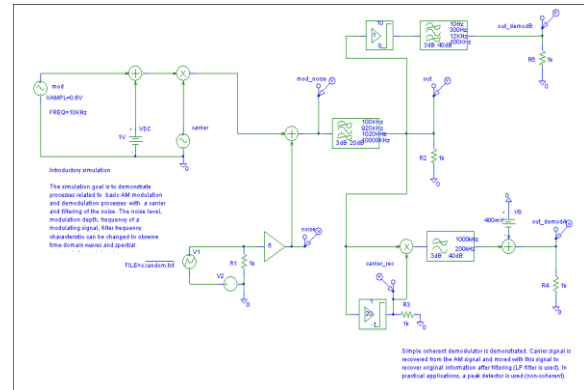

Figure 1: AM modulator and Demodulator

The circuit in Figure 1 includes AM modulator (transmitter) and demodulator. On the left is the transmitter, on the right – two types of demodulators. Lower right corner circuit shows the demodulator that includes the simple carrier reconstruction circuit and low pass filter (synchronous demodulator), upper right image is asynchronous demodulator with an ideal rectifier and a low pass filter. Center lower circuit is a pseudo random noise generator – the noise source “reads” the numbers from the text file and produces the signal whose amplitude and “spike” repetition could be modified, as well as the other pseudorandom sequence could be easily introduced as the new text file..

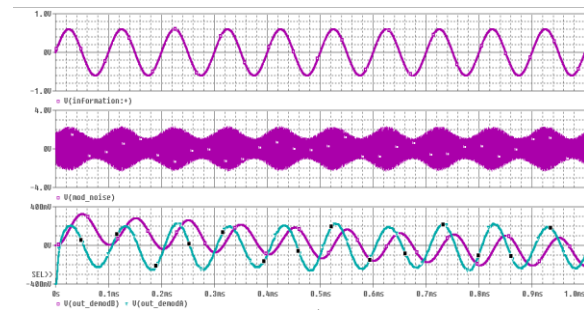

Figure 2: Time domain signal

The time-domain signals, shown in Figure 2, include the information signal, modulated carrier, and two demodulated waves – from upper and lower demodulators.

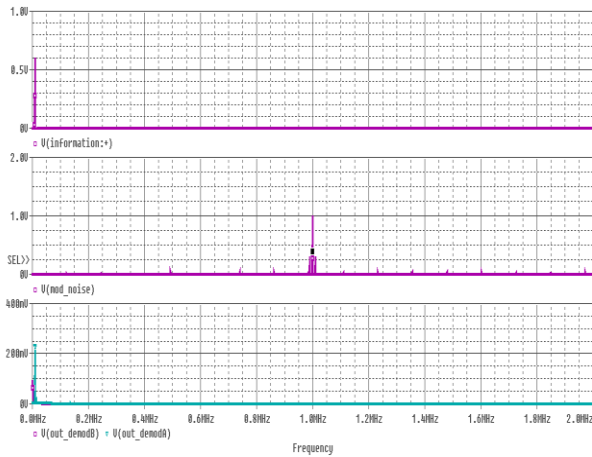

Figure 3: Spectra of the waves: information signal, modulated wave, demodulated signals after filtering.

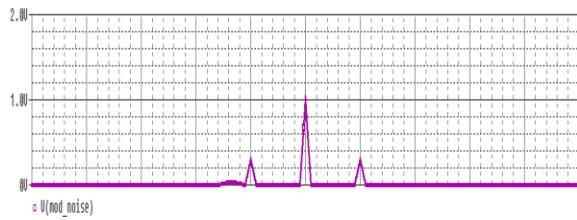

Figure 4: Modulated signal spectrum with noise after filtering

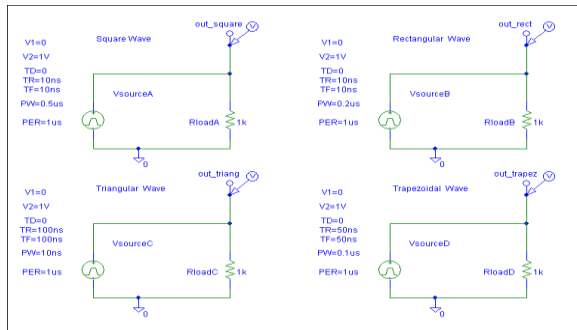

Figure 5: Multiple circuits to generate different wave forms.

Four circuits as shown in Figure 5 are used simultaneously to demonstrate Fourier analysis: square, rectangular, trapezoidal, and triangular periodic waves are generated and spectra are displayed in Figure 6.

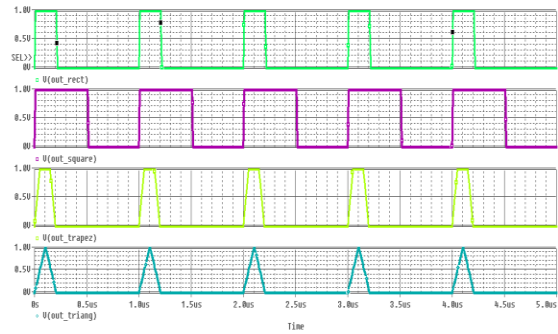

Figure 6: Time-domain waves from circuits shown in Figure 5

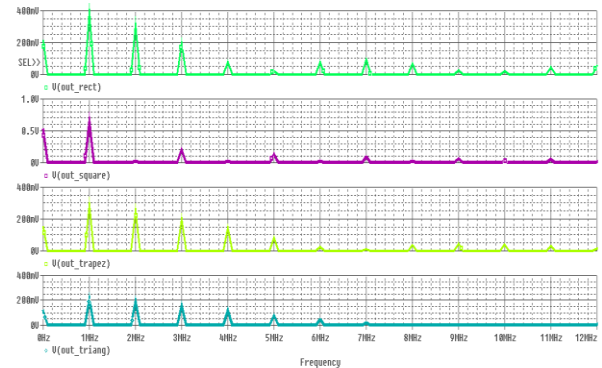

Figure 7: Spectral representations

Spectral representations as shown in Figure 7 are : top- rectangular (rich spectrum as far as the number of harmonics, broad main lobe (1/pulse duration width), second for square wave shows eliminated even harmonics, trapezoidal – “slower” wave transitions show smaller peaks in comparison with rectangles, triangle wave spectrum decays quickly for HF due to slowest transitions.

Next simulations introduce the students to baseband modulators and demodulators such as delta and pulse with modulation (PWM) units.

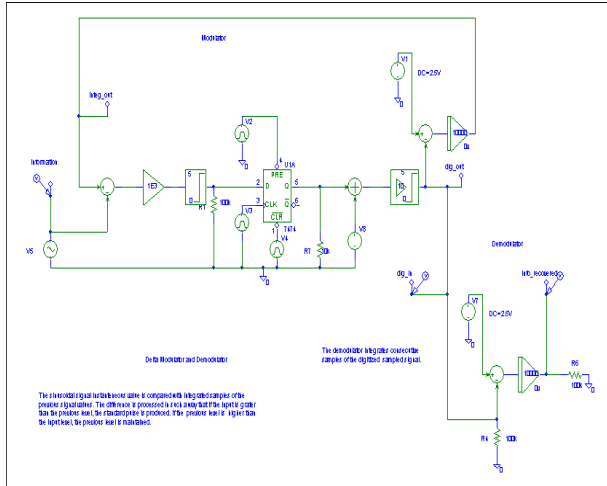

Figure 8: Modulator/demodulator

Delta modulator (upper part) and demodulator (lower part), both “unpacked to show details. The waves shown in Figure 9 demonstrates analog into “zero-one” signal conversion, and “zero-one” conversion, back into analog signal to reconstruct original information. The output signal can be more filtered to make it smoother, but there could be a problem with encoding signal of a higher frequency.

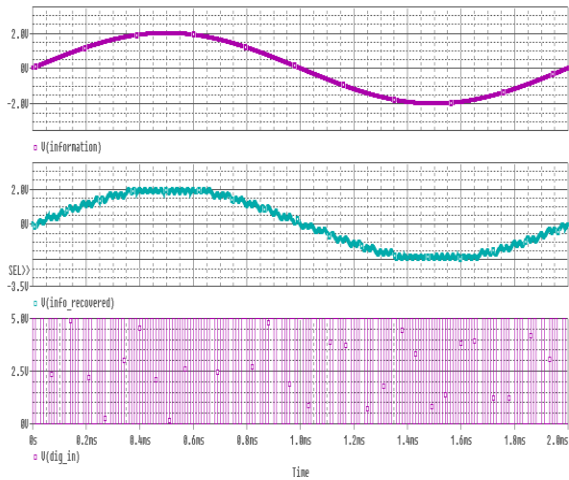

Figure 9: Output waveform for Figure 8

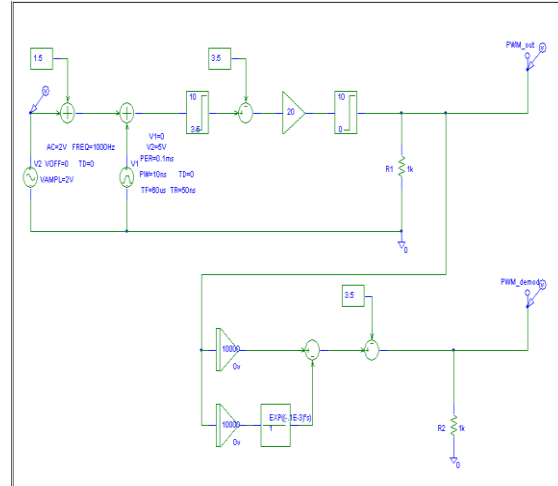

Figure 10: PWM circuit with modulator and demodulator

Figure 10 shows PWM Pulse Width Modulator – larger signal levels correspond to broader pulses, smaller values – narrower pulses, Lower Circuit – demodulator.

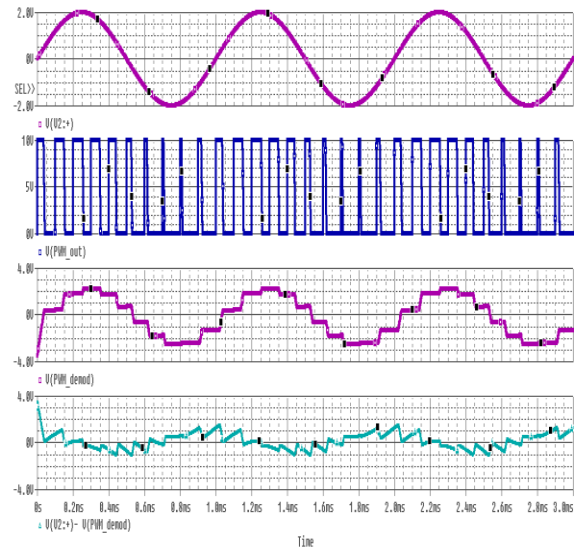

Figure 11: Output waveform for Figure 10.

Figure 11 shows: Top- information signal, second- PWM wave, third – reconstructed original signal, bottom – difference between original information and reconstructed signal.

Several examples, shown below demonstrate band pass modulation and demodulation processes.

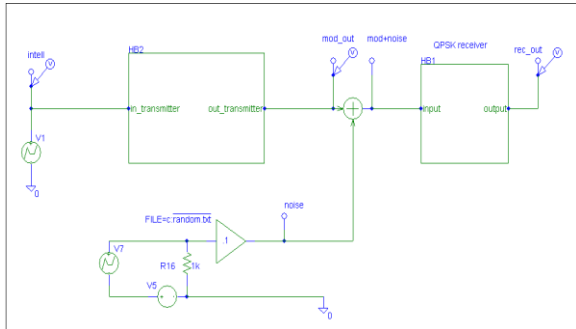

Figure 12: QPSK circuit

QPSK – quadrature phase shift keying system - shown in Figure 12, is fully integrated. Transmitter (two level system with two sub-blocks shown in Figures 13 and 14), on the left splits the digital arbitrary signal from the source (intell) to save the bandwidth, sine and cosine carriers “carry” even and odd digital signal components, both modulated signals are added and transmitted, noise is added (from the bottom circuit). QPSK receiver reconstructs the intelligence signal.

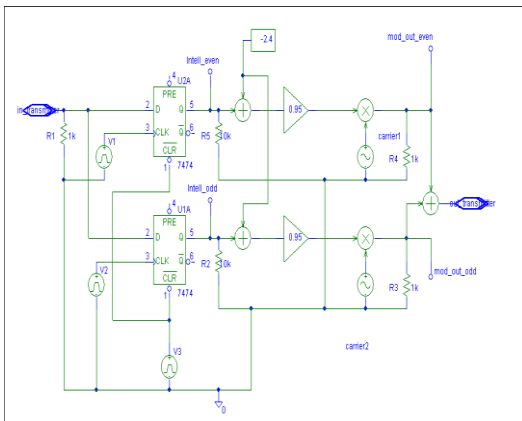

Figure 13: Transmitter with two channels and sine, cosine carriers.

Figure 13 shows the way the digital intelligence signal coming from the source V1 (Fig. 12) is divided between two separate channels (D-flip-flops) and the upper part of intelligence signal (even) modulates the sine carrier, lower part (odd) modulates the cosine carrier. Both modulated signals are combined together (added) for final transmission.

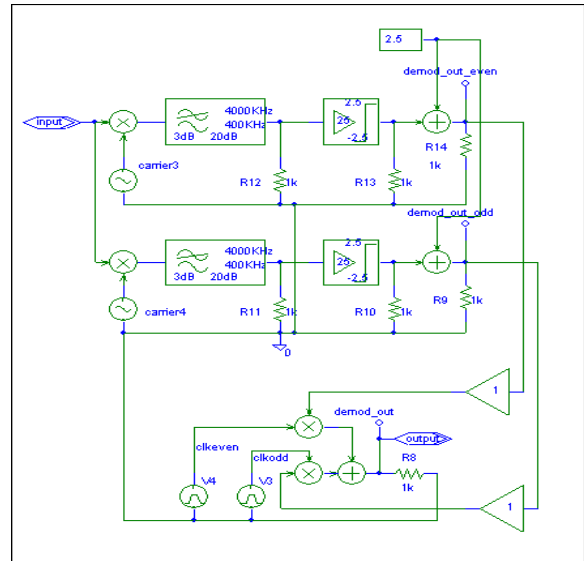

Figure 14. Receiver circuit

In Figure 14, Receiver splits the channels, decodes odd and even parts of the intelligence signal in two coherent demodulators, and combines these parts to reconstruct original information.

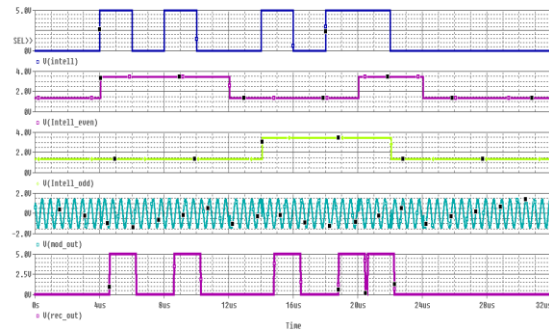

Figure 15. Output waveforms for Figure 14.

In Figure 15, the top signal is the original digital signal (intelligence), second and third from the top are even and odd parts of the intelligence, split in the transmitter to slow down modulation process and save spectrum, fourth signal is the modulated carrier, and the last signal is reconstructed original intelligence.

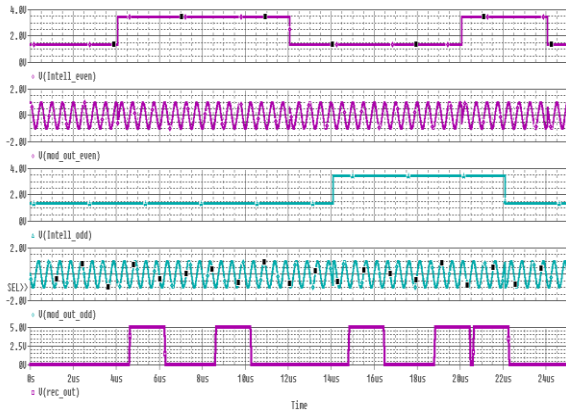

Figure 16: Output waveforms

In Figure 16, the top signal is the even part of intelligence, second signal is the modulated carrier (sine) by the even part, third signal is the odd part of intelligence, fourth signal is the cosine carrier modulated by odd part, the last signal is the –reconstructed intelligence.

The FSK system – frequency shift keying – Integrated System, and two sub-blocks are shown in Figures 17 to 19. The Voltage Controlled Oscillator (VCO) is modulated by the info source. Large level of noise is added within the transmission channel. Phase Locked Loop (PLL) system receives and reconstructs the info(rmation) signal.

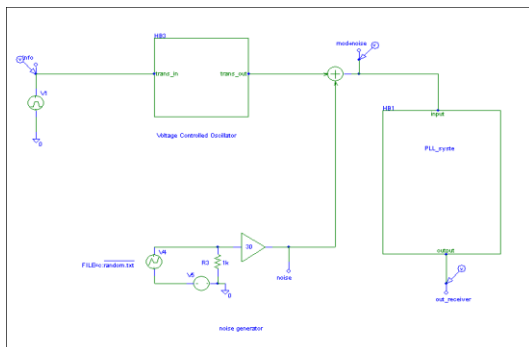

Figure 17: FSK circuit with transmitter and receiver sub blocks

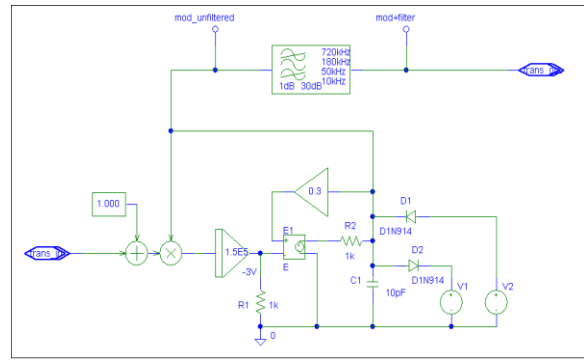

Figure 18: FSK transmitter sub block

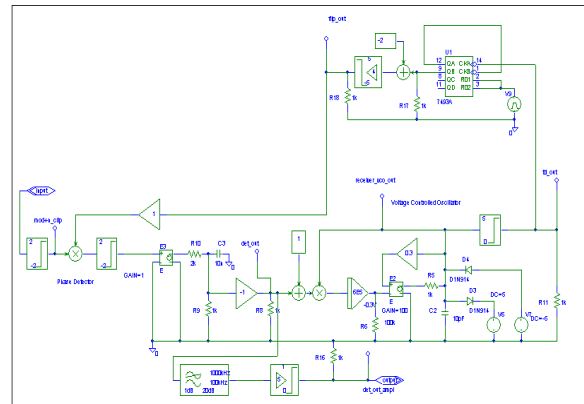

Figure 19: FSK receiver sub block with PLL system

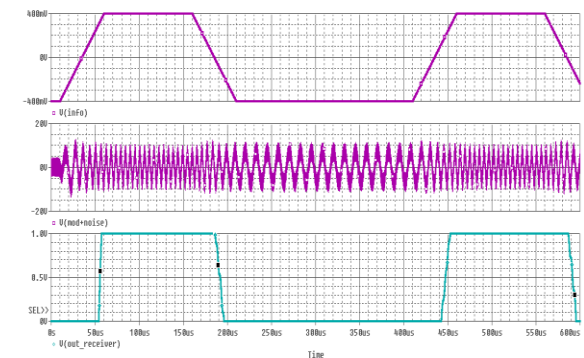

Figure 20: Output waveforms

Digital information signal is encoded in frequency changes, and this digital signal is decoded in the receiver. Noise signal is added to the modulated signal.

The following Figures 21 to 23 demonstrate the operation of CDMA (Code Division Multiple Access) systems.



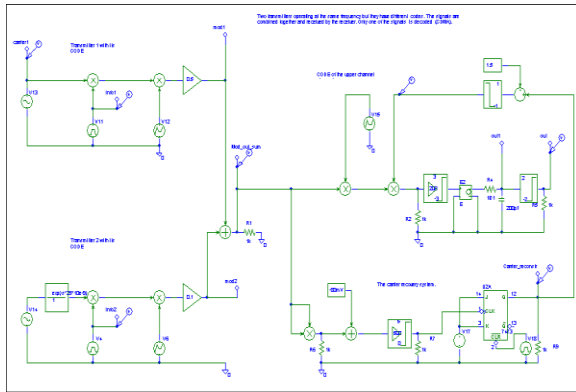

Figure 21: CDMA circuit

In Figure 21, on the left, there are two transmitters sending two different digital messages on the same frequency. Phase Shift Keying (PSK) modulation is used. The goal of this simulation is to demonstrate how the desired intelligence signal is decoded in the presence of the other, undesired, or interfering signal in such a case when the same carrier frequency is shared among many communication units. The transmitters employ two different digital codes added to the messages. The receiver (upper and lower right hand side) decodes only one message (upper transmitter message) since its internal code is set to read only the code of this transmitter. The lower right hand side corner shows the carrier recovery system. This carrier is used to demodulate the transmitted signal.

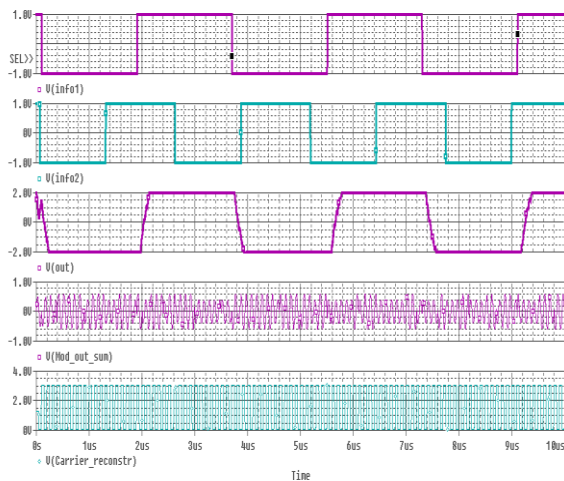

Figure 22: Output waveforms

In Figure 22, Wave 1 (top) shows the channel 1 information signal (upper transmitter), Wave 2 (below top) shows channel 2 information signal (lower transmitter), Wave 3 shows the demodulated signal that looks very much like channel 1 signal digital signal), Wave 4 shows the transmitted signals (with the carriers) from two transmitters, and Wave 5 shows the reconstructed carrier that is used for synchronous demodulation.

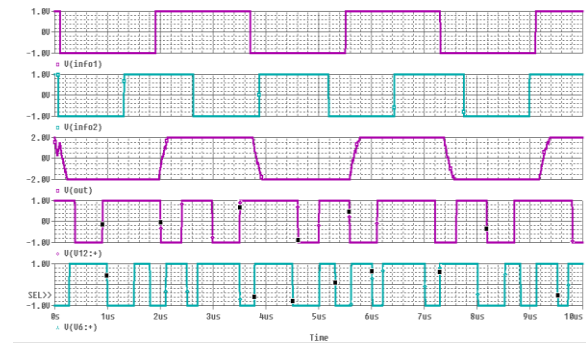

Figure 23: Output waveform for Figure 20.

In Figure 23, Wave 1 Wave 2 and Wave 3 are as before. Last two waves show two different codes for two separate transmitters. First code is used in the receiver to decode the signal from upper transmitter.

**Conclusion**

In this paper we have demonstrated the use of PSPICE (using free student edition) for teaching many circuits in a undergraduate course on Circuits and also in a communication course. The PSPICE circuit and simulation discussed in the paper would make excellent additions to the class room or laboratory of any senior undergraduate electronics course.

References:

## Session 4D

1. Dennis Silage, Augmenting Hardware Experiments with Simulations in Digital Communications, Proceedings of the 2003 American Society for Engineering Education Annual Conference & Exposition, Session 2632.
2. Andrew Rusek, Barbara Oakley, PSpice Applications in the Teaching of Communication Electronics, Proceedings of the 2001 American Society for Engineering Education Annual Conference & Exposition, Session 2793.
3. Bernard Sklar, Digital Communications, Fundamentals and Applications, Prentice Hall PTR, 2001.
4. John G. Proakis, Masoud Salehi, Digital Communications, McGraw-Hill, 2008.
5. System View, ELANIX, INC., Student Edition.
6. Simon Haykin, Communication Systems, John Wiley & Sons, Inc., 2007.