

Teaching Programming Fundamentals Using Hands-on Experiential Learning Techniques

Dr. Todd Hamrick, PhD
West Virginia University, Morgantown, WV 26508
Email: Todd.Hamrick@mail.wvu.edu

Abstract

Many university first year programs are working to integrate hands on projects into their programming curriculum. This work describes an innovative, successful hands-on project used at West Virginia University for teaching MATLAB programming. The project required students to design a security system for a building or outdoor area. The security system was monitored using simple sensors wired to an Arduino controller, which in turn was tethered to computers running MATLAB. The MATLAB programs were required to monitor the system, sound distinct alarms depending on which sensors were triggered, and to maintain sensor triggering history. This required the use of the programming tools taught in the course, as well as teamwork and project management tools. Each group of students went beyond the minimum requirements of the project, and implemented additional components to their systems. Feedback was overwhelmingly positive, with students commenting in course feedback forms that the project helped to make the programming more relevant. This was an inexpensive way to implement a successful hands-on project into a programming course.

Introduction and Background

West Virginia University uses a common first year engineering curriculum, including two consecutive introductory courses, as is in common first year curricula.¹⁻⁴ The second course is primarily a fundamental MATLAB programming class. The course is project based, usually requiring three projects per semester, with projects generally requiring software input and output. Students are never required to build anything.

Hands on learning is well documented as an effective teaching tool for kinesthetic learners.^{5,6} Such students seemed to be underserved in the course, so efforts are underway at WVU and elsewhere to create more hands-on and real world application projects.⁷ On their own initiative students specifically requested hands-on projects in the classroom.

Implementation of project based courses can be challenging, but many universities have created successful hands-on project based courses. Penn State has been using robots of its own design since the mid-1990's. They have had success with a group size of three students per group.⁸ Northeastern University uses semi-custom kits to teach programming and electronics with a high level of positive student feedback.⁴ Both Louisiana Tech University and Portland State University have used C programming to control Arduino controllers in projects.^{2,9}

This work describes a low cost, re-usable and flexible hands-on project that was used in WVU's second semester programming course with great success.

Discussion

In fall of 2012 one section of twenty four students in this course were assigned a final project which required that they develop a home or business security system, and to build a physical model to demonstrate it. Working in teams of three, they were required to program and control the system using MATLAB and an external controller. Students were provided with an Arduino Uno controller, a breadboard, and some basic electronic components including momentary switches and a buzzer. Reusable kits were created from the components, which were purchased commercially for around \$40 per kit. The kits had been purchased for a different project with similar goals for summer activities using a university grant. They were re-used in the fall semester, and no additional money was spent for this course offering. Students were also provided pre-written function files that allowed MATLAB to communicate with the Arduino.

The system was required to have the following capabilities:

- Monitor at least three sensors.
- Recognize and be capable of distinguishing each when triggered.
- Output a distinct set of tone signals to the beeper for each when triggered.
- Maintain a record of each time each sensor was triggered.
- Output a table upon command indicating the time that each was triggered since the last re-set of the system.
- Construct a physical model such as a building to demonstrate the system. This was intentionally open ended so that students could expand upon the project.
- Write a technical report detailing the system.
- Create a technical poster and make a short poster presentation about the project.

Programming skills required to effectively complete the project included the use of pseudo code, loops, nested loops, conditional statements, relational operators, dummy indexes, matrix analysis, formatted printing, function files, debugging, and other techniques taught in the course. Additional course objectives that the project was intended to address included teamwork, project management, technical report writing, technical posters and oral presentations. Because wiring is not part of the course, students were led through how to wire the breadboard. An example of how the system should be wired was provided, and appears in Figure 1. This was intended as an example to be expanded upon for additional sensors. Students wired the sensors into their constructed models. They were responsible for providing their own materials for their models.

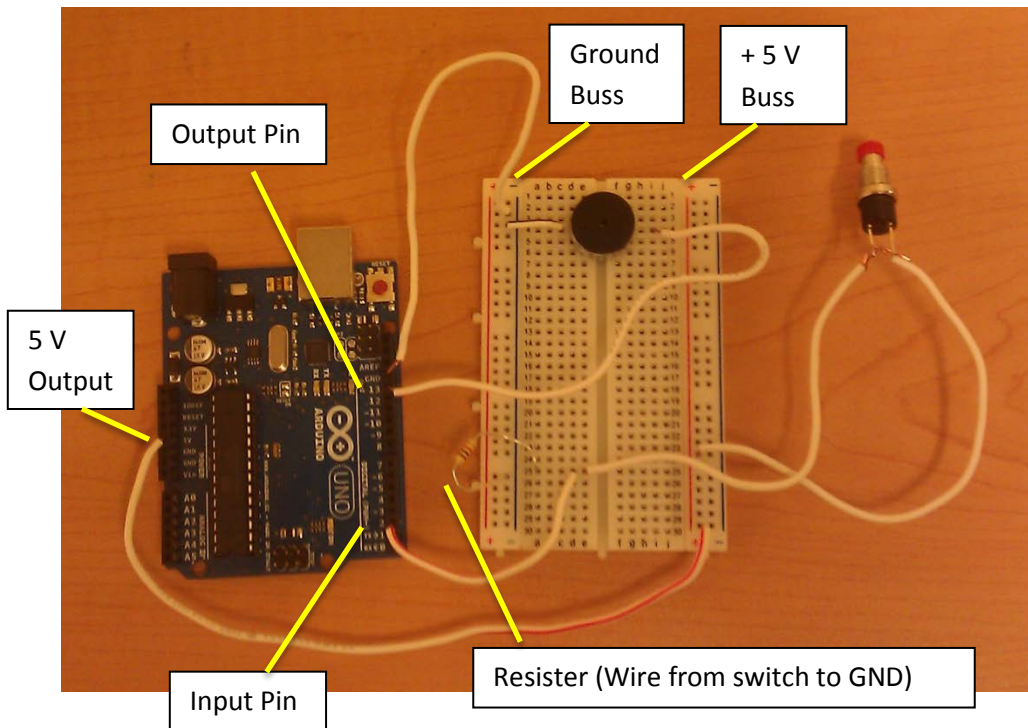

Figure 1 Example of wiring the Arduino, the breadboard, the beeper, and one of the sensors

Results

Student response to the project was excellent. They constructed models using a wide variety of materials such as cardboard, Lego-bricks, clear acrylic sheets, and even a doll house. Each of the eight teams added some unrequired element to make the project more interesting or to show off their increased understanding. Two of the teams simply added a fourth sensor. While this was relatively simple, it did require that they modify the MATLAB function files to accommodate additional input and output control pins, which required a more sophisticated level of programming than would have been required by doing only the minimum requirement.

One team added a bank of LED lights that indicated different colors when different sensors were activated. Another applied the system to an outdoor area, building a model of gas drilling rig enclosure. One team replaced the momentary switches provided with optical sensors for non-contact sensing, and another made a custom housing for the controller and breadboard and incorporated additional controls. In each case the students expanded upon the minimum requirements of the project in such a way that they had to learn more than was taught in the class. About half sought additional help from the instructor, while the others were able to figure out the expansions on their own.

Examples of two of the models can be seen in Figure 2 and Figure 3. The system that was integrated into the doll house in Figure 2 had an added two features not required in the project. A housing for the controller and breadboard was created so that the system could be hidden and more professional looking. An on/off switch was incorporated into the housing so that the

program could be controlled by a user in the house. The system in Figure 3 used four sensors, and hid the controller and breadboard in the “attic” part of the building.



Figure 2 Doll house used to model the security system. Note the black housing in the upper level, with an on/off switch for the system incorporated.



Figure 3 Example of one of the projects that used four sensors. The controller and breadboard were hidden under the roof, and the wiring was neatly run along the walls. Some of the MATLAB control can be seen on the laptop screen.

The additional effort that students put into the project translated into a better experience, and possibly improved learning, as they reported themselves. Written feedback was taken from the standard student evaluations done at the end of the semester. No special feedback or surveys were requested, so student feedback about the final project was spontaneous and not elicited. Written feedback about the hands-on project was quite positive.

Two thirds of those who responded with open ended comments mentioned the project, all of which were positive. Students felt that they gained more from the hands-on project than any

other part of the course, and that they could recognize the real-world relevance of MATLAB programming. Some of the quotes included:

The projects assigned were very hands on and practical.

The projects helped a lot in understanding how to apply MATLAB to real scenarios.

The majority of my learning came from the projects.

...allowed us to do a project that was more advanced and different from the regular class, and it was so much fun.

These are in contrast to comments found on the evaluations of students who took the conventional version of the course in the spring, all taught by the same instructor using the same book. In the 50 comments from four sections, there was not any mention of a specific project.

There is some evidence that the students learned more as well. Those who participated in the class with hands-on projects scored an average of 5 percentage points higher, and had a median 4 points higher on a comprehensive final exam than those who completed only computational projects.

Continued Work

Efforts continue to develop more hands on projects for this course. Some will make further use of the tethered controllers, such as a robotic version of the course that is in development after pilot programs in summer 2012 and 2013. Others will use MATLAB as an analysis tool, and require construction of models based on the analytical outcome.

The wiring shown in Figure 1 is just one example of how such a system could be used. If wiring is part of the course curriculum, systems that require more advanced wiring could be easily imagined. In those that do not require the use of circuitry, simple circuits such as this can be utilized.

Conclusions

This class used the same book and curriculum as is used in other class, but added a hands-on final project. Students enjoyed the project, and nearly all put in more effort than was required by the assignment. Students who were provided the opportunity to work with their hands enjoyed course more, put in more effort, and seem to have learned more than students who completed purely computational projects. Unsolicited feedback was highly positive.

The project was implemented using inexpensive and re-usable kits. Such systems could be adapted by other institutions seeking to increase hands on projects in programming courses.

References

- [1] Dunne, B., Blauch, A., Sterian, A. (2005). The Case for Computer Programming Instruction for All Engineering Disciplines. *Proceedings of the 2005 American Society for Engineering Education Annual Conference & Exposition*
- [2] Hall, D., H. Hegab, and J. Nelson. (2008) Living WITH the Lab - A Freshman Curriculum to Boost Hands-on Learning, Student Confidence and Innovation. *ASEE/IEEE Frontiers in Education Conference, Saratoga Springs, NY. October 22-25, 2008, IEEE.*
- [3] McKnight, S., Tadmor, G., Ruane, M., Rodriguez-Solis, R., & Saulnier, G. (2002). Creating 'High-Tech Tools and Toys Lab' Learning Environments at Four Universities. *ASEE/IEEE 32nd Frontiers in Education Conference, 2: S3E7-6.*
- [4] Jaeger, B., Freeman, S., Whalen, R., (2012) Programming is Invisible or Is It? How To Bring A First Year Programming Course To Life. *American Society of Engineering Education Annual Conference, San Antonio, TX*
- [5] Felder R., Silverman, L., (1988) Learning and Teaching Styles In Engineering Education. *Engr. Education, 78(7), 674-681*
- [6] Lumsdaine, L., Lumsdaine, E., (1995). Thinking Preferences of Engineering Students: Implications for Curriculum Restructuring. *American Society for Engineering Education, Journal of Engineering Education Vol 84, No. 2.*
- [7] National Academy of Engineering. 2012. Infusing Real World Experiences into Engineering Education. The National Academies Press, Washington DC.
- [8] Avanzato, R. (1998). Collaborative Mobile Robot Design in an Introductory programming course for Engineers. *Proceedings of the American Society for Engineering Education Annual Conference & Exposition, Seattle, WA.*
- [9] Recktenwald G. & Hall D. (2011). Using Arduino as a Platform for Programming, Design, and Measurement in a Freshman Engineering Course. *Proceedings of the American Society for Engineering Education Annual Conference & Exposition, Vancouver, British Columbia, Canada.*